

EDN[®]

VOICE OF THE ENGINEER

DEC **15**
Issue 24/2010
www.edn.com



Prying Eyes: Paper
Jamz guitar Pg 20

EDN.comment Pg 8

A good holiday-
season project Pg 18

Mechatronics
in Design Pg 22

Design Ideas Pg 43

Tales from the Cube Pg 50

HOT TECH

**DISPLAY-
TECHNOLOGY
ENHANCEMENTS:**
CHANGE IS
THE ONLY
CONSTANT
Page 24

**MULTIPHYSICS
SIMULATION
ENHANCES
ELECTRONICS
SYSTEM
DESIGN**
Page 34

**HOT 100
PRODUCTS
OF 2010**
Page 40

**ONE
CLICK
AWAY**



www.digikey.com

PREMIUM SELECTION PERSONALIZED SERVICE



Authorized distributor for more than 440 of the world's most trusted manufacturers.*

The industry's broadest product selection available for immediate delivery

**www.digikey.com
1.800.344.4539**

*Digi-Key is an authorized distributor for all supplier partners. New products added daily. © 2010 Digi-Key Corporation, 701 Brooks Ave. South, Thief River Falls, MN 56701, USA



A smarter approach to metering.



Cirrus Logic Analog Front Ends (AFEs) are the first choice for today's smart metering solutions.

Unlike expensive SOCs, our AFEs allow the flexibility of designing with a wide range of third party microcontrollers to optimize for your specific application requirements.

Don't spend time worrying about how to make an SOC fit into your design. Make the smarter choice for your metering needs with Cirrus Logic's flexible, cost-effective AFE solutions.

Power up at www.cirrus.com/ednmeter and register for a free evaluation board.



Windows® Life without Walls™ Dell recommends Windows 7.



The power to do more

Let your vision take shape.



Unleash your creativity and imagine the possibilities. Then watch as they become reality with the power of Dell Precision™ workstations and Autodesk® BIM software.

Dell Precision™ workstations deliver the performance and graphics needed to run demanding applications with ease. Now your team can use data-rich modeling to evaluate new design options, predict building performance and communicate more productively.

- Genuine Windows® 7 Professional
- Scalable options – select systems are available with up to 192GB of memory* and 7.5TB of internal storage
- A full range of desktop, rack and mobile workstations to fit your needs
- ISV-certified for 95 leading applications, including Autodesk®
- Stay up and running with Next Business Day on-site warranty options or optional 24/7 Dell ProSupport™ covering applications from 25 ISV vendors, including Autodesk.



Get Equipped ▶

Find your ideal configuration online.
Go to Dell.com/smb/Vision or
call your sales rep at 1-888-378-3355



Microsoft®

Office Home and Business 2010

PC
Completed

Do More Business in More Places – Microsoft® Office 2010 Now Available on Dell Systems

Microsoft® Office 2010 includes the tools and capabilities you need to organize, present and track your business whether you are in the office or on the road.

*Actual capacity varies with preloaded material and operating environment and may be less. Significant system memory may be used to support graphics, depending on system memory size and other factors. Intel, the Intel logo, Xeon, and Xeon Inside are trademarks or registered trademarks of Intel Corporation in the U.S. and other countries. Attn Warranties, One Dell Way, Round Rock, TX 78682 or visit dell.com/warranty. Remote Diagnosis is determination by online/phone technician of cause of issue, may involve customer access to inside of unit and multiple or extended sessions. If issue is covered by Limited Hardware Warranty and not resolved remotely, technician and/or part will be dispatched usually within 1 business day following completion of Remote Diagnosis. Availability varies. Other conditions apply.

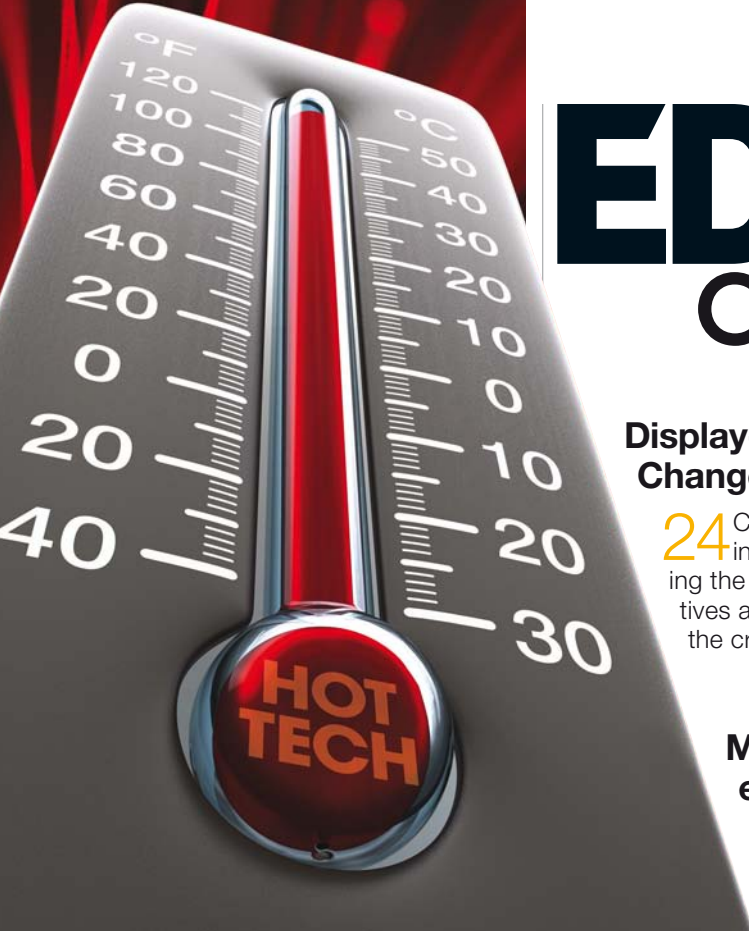

EDN 12.15.10 contents

Display-technology advancements: Change is the only constant

24 Conventional LCDs' industry dominance might seem insurmountable, but, not too long ago, people were saying the same things about CRTs. Upstart revolutionary alternatives aspire to ascend to the throne, but LCDs intend to retain the crown.

by Brian Dipert, Senior Technical Editor

Multiphysics simulation enhances electronics system design

34 Adding models of thermal and optical behavior provides more complete verification of performance and reliability.

by Mike Demler, Technical Editor

pulse Dilbert 14

13 Six-core DSPs enable software selection of 3 or 4G air interfaces

14 Hard-disk drives' burgeoning capacities outshine those of solid-state drives

16 Voices: Avnet's Roy Vallee: back to balance in 2011

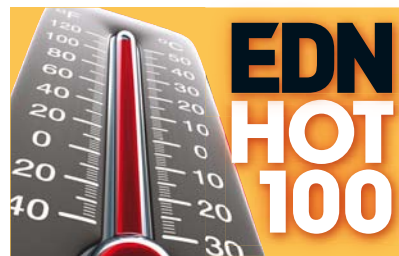

The Hot 100 Products of 2010

40 Which products made the cut this year? Read our list of the best of the best—the products and technologies that in 2010 really grabbed the attention of our editors and our readers.

COVER: COMPOSITE IMAGE BY TIM BURNS.
THERMOMETER: KTSIMAGE/ISTOCKPHOTO.COM;
BACKGROUND: MERRYMOONMARY/ISTOCKPHOTO.COM

DESIGN IDEAS

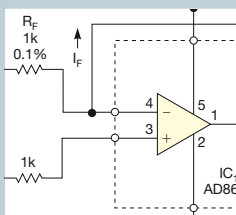

43 High-side current-shunt monitor offers reduced error

45 Make a quick-turnaround PCB for RF parts

46 PLL filter blocks undesired frequencies

46 Logic probe uses six transistors

Over 5000 Standard **PICO** Transformers and Inductors

From .19" ht.

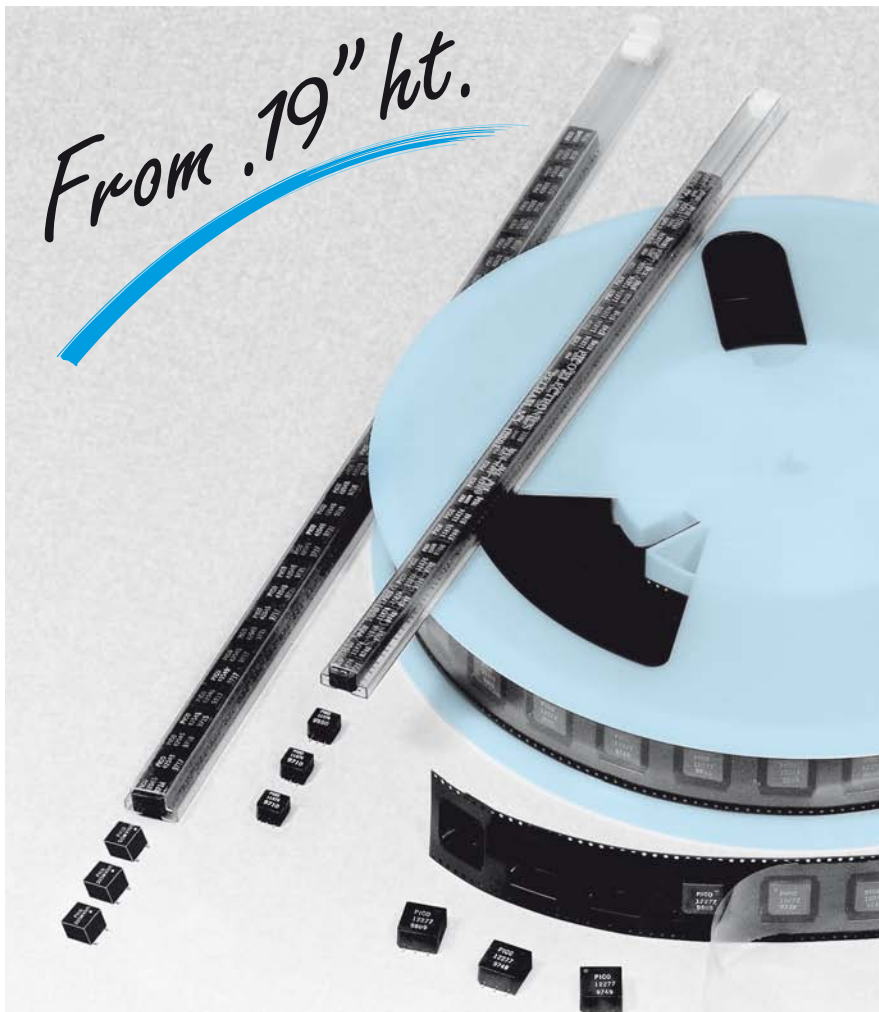

Surface Mount (and Plug-In)

Audio Transformers

Impedance Levels 10 ohms to 250k ohms, Power Levels to 3 Watts, Frequency Response ± 3 db 20Hz to 250kHz. All units manufactured and tested to MIL-PRF-27. QPL Units available.

Power & EMI Inductors

Ideal for noise, spike and Power Filtering Applications in Power Supplies, DC-DC Converters and Switching Regulators

Pulse Transformers

10 Nanoseconds to 100 Microseconds. ET Rating to 150 Volt Microsecond, Manufactured and tested to MIL-PRF-21038.

Multiplex Data Bus Pulse Transformers

Plug-In units meet the requirements of QPL-MIL-PRF 21038/27
Surface units are electrical equivalents of QPL-MIL-PRF 21038/27.

DC-DC Converter Transformers

Input voltages of 5V, 12V, 24V And 48V. Standard Output Voltages to 300V (Special voltages can be supplied). Can be used as self saturating or linear switching applications. All units manufactured and tested to MIL-PRF-27.

400Hz/800Hz Power Transformers

0.4 Watts to 150 Watts. Secondary Voltages 5V to 300V. Units manufactured to MIL-PRF-27 Grade 5, Class S (Class V, 155°C available).

DELIVERY-stock to one week
for sample quantities

PICO

Electronics, Inc.

143 Sparks Ave. Pelham, NY 10803 • Call Toll Free 800-431-1064 • fax: 914-738-8225

Send for free 180 pg PICO Catalog

See PICO's full Catalog Immediately on the internet

www.picoelectronics.com

E-mail: info@picoelectronics.com



48



50

DEPARTMENTS & COLUMNS

- 8 **EDN.comment:** Electronica 2010: Going green, often sight unseen
- 18 **Baker's Best:** A good holiday-season project
- 20 **Prying Eyes:** Christmas toys: Paper Jamz guitar relies on printed electrodes and connectors
- 22 **Mechatronics in Design:** PLM and mechatronics
- 48 **Product Roundup:** Power Sources
- 50 **Tales from the Cube:** The sharpest tool in the shed

EDN online contents

www.edn.com

ONLINE ONLY

Check out these Web-exclusive articles:

E-readers to open up \$1 billion semiconductor opportunity in 2011

Increasing shipments of e-readers create new opportunities for microprocessor and memory vendors, according to In-Stat.
[→www.edn.com/101215toca](http://www.edn.com/101215toca)

Agilent teams with Harvard's Wyss Institute on biologically inspired engineering

One goal of the partnership is to provide deeper insight into the way physical forces and the mechanical properties of living tissues influence cell behavior and contribute to the onset and progression of disease.
[→www.edn.com/101215tocb](http://www.edn.com/101215tocb)

READ ANY GOOD DESIGN IDEAS LATELY?

[→www.edn.com/designideas](http://www.edn.com/designideas)



FROM EDN's BLOGS



How electronics technology keeps ripping off the world of Harry Potter

From PowerSource, by Margery Conner

We live in an age of marvels. It's easy to forget that the industry that we work in lies beneath the vast majority of them, and we are privileged to be participants.

[→www.edn.com/101215tocc](http://www.edn.com/101215tocc)

Employment is on its way up, but is it up enough?



From Now Hear This!, by Suzanne Deffree

Broadcom sits atop a recent list from the Orange County Business Journal naming

companies in the area hiring talent for local operations.

[→www.edn.com/101215tocd](http://www.edn.com/101215tocd)

Simpler Power Conversion

IR's SmartRectifier™ chipset for AC-DC power converters dramatically simplifies design and improves efficiency.



SmartRectifier™ ICs

Part Number	IR1166 SPbF	IR1167A SPbF	IR1167B SPbF	IR1168 SPbF	IR1166Z SPbF	IR11672A SPbF	IR1168Z SPbF
Package	SO-8						
V _{cc} (V)	20						
V _{ret} (V)	200						
Sw Freq. max (kHz)	500					400	
Gate Drive ±(A)	+1/-4	+2/-7	+1/-4	+1/-4	+2/-7	+1/-4	
V _{max} Clamp (V)	10.7	10.7	14.5	10.7	10.7	10.7	10.7
Min. On Time (ns)	Program. 250-3000			750	Program. 250-3000		
Enable Pin	Yes	Yes	Yes	No	Yes	Yes	No
Channel	1		2		1		2
Automatic MOT Protection	No	No	No	No	Yes	Yes	Yes

For more information call
 1.800.981.8699 or visit
www.irf.com

International
IR Rectifier
 THE POWER MANAGEMENT LEADER



BY BRIAN DIPERT, SENIOR TECHNICAL EDITOR

Electronica 2010: Going green, often sight unseen

“Green” technologies had a substantial presence at this year’s Electronica, which took place last month in Munich, Germany. STMicroelectronics’ chief executive officer called them out as among the key trends that his company was planning to harness for continued semiconductor success in the future, and his executive peers on the panel echoed his aspirations. More generally, green was in at Electronica; nearly every display suite’s eye-catching aspirations included artwork and verbiage documenting the relevant company’s environmentally sensitive leanings, and many of the vendors’ booths showcased technology demonstrations of various power-saving product capabilities.

Pardon my negativity, but I walked away with some of the same cynicism that I experience at every supposedly green Consumer Electronics Show. Don’t get me wrong; saving power is an honorable aspiration. Certain aspects of the companies’ pitches always resonate with me as a lifelong member of the Sierra Club. And I applaud STMicroelectronics’ focus on green technologies as key industry trends.

The nexus of my skepticism, though, lies in the fact that making a product green often seems a convenient platitude to ensure continued—if not accelerated—materialism on the part of the end customer. After all, isn’t the most power-efficient product the one that burns no power at all? Yet, sticking a picture of a green leaf, a flower, a tree, or a panda on a product’s retail packaging enables consumers to rationalize its purchase, regardless of whether it’s something they need or want, thereby further boosting the home’s aggregate current draw.

Thankfully, I observed in Munich numerous examples of practical, in-use and often subtly implemented environmentally sensitive technologies that some-

what counterbalanced my pessimism. Europe is, as many of you know, a demographic leader in going green, the pragmatic result of its much higher energy prices versus, for example, the United States due to factors such as less available domestic supply, fewer artificially price-lowering government subsidies, higher government taxes and regulatory influences, and the like. You can see the impact of these factors, for example, in the smaller average size of vehicles versus those in the United States. On the other hand, had the driver of the taxi I took from the airport to my hotel spoken more English, I might have mentioned to her the gas-guzzling downsides of driving her Mercedes-Benz at nearly 200 kph, or approximately 120 mph, peak speeds on the Autobahn.

But I knew I wasn’t in Kansas anymore when I stepped out of the elevator at the hotel and the dim hallway lights automatically brightened; I hadn’t previ-

ously experienced such precise motion-sensor management. Speaking of lights, their nonincandescent dominance in both fluorescent and LED forms everywhere I looked in Munich was impressive. Then, one day at the subway station, the escalator didn’t seem to be working, but the stairs next to it were jammed with people. I decided to walk up the escalator instead and was surprised to feel it begin to move under my feet when I stepped on it. I experienced a similar situation at Munich Airport; the molasses-slow conveyor belt smoothly accelerated when I started striding on it.

Some of what I observed was, I suspect, fundamentally cultural in nature. There were plenty of automobiles; Germany is, after all, the home of Audi, BMW, Mercedes-Benz maker Daimler AG, Opel, Porsche, and Volkswagen. But most folks seemed to instead be using the robust Munich public-transit system; subways were packed during rush hours. To get from the transit stations to their destinations, people relied on walking, biking, and using scooters.

I believe that California, for all its environmentally friendly claims, has a lot to learn about not only talking the talk but also walking the green walk, after what

I’ve seen in Munich. Admittedly, this automobile-crazed state

is, unlike the East Coast, for example, infrastructure-tailored for individual-transportation vehicles, and retrofitting it for robust public transit will be costly and time-consuming. Neither issue is politically palatable. Yet, although hybrid and, eventually, electric vehicles, along with green utility power sources, will play their part in reducing California’s and the United States’ carbon footprints, mass transit is a prerequisite to more notable power-consumption improvements—not to

mention the radical suggestion of more frequently strapping on the walking shoes. **EDN**



Contact me at brian.dipert@ubm.com.



Plug in to our Power Tools

Make better, faster power inductor choices with Coilcraft's powerful web tools.

Start with an IC, a converter topology, or a list of electrical and mechanical specs. In seconds you'll get a list of every Coilcraft part

that could work for you, complete with price information. A few more clicks gives you a detailed analysis of core and winding losses.

Check out our complete power designer's toolbox at www.coilcraft.com/powertools



ORDER DIRECT
 BUY.COILCRAFT.COM
 800-322-2645

OVERNIGHT
 DELIVERY
 ORDER BY 5



Coilcraft[®]

www.coilcraft.com 800/322-2645

We built a scope with
the fastest acquisition
system ever

so you can capture
the rarest glitches.



1. Visit:
scope-of-the-art.com/ad/quiz/edn

2. Play:
The Scope Masters

3. Win: A Scope

See for yourself
www.scope-of-the-art.com/ad/scope/ad



ROHDE & SCHWARZ

EDN

PUBLISHER, EDN WORLDWIDE

Russell E Pratt, 1-781-869-7982;
russell.pratt@ubm.com

ASSOCIATE PUBLISHER, EDN WORLDWIDE

Judy Hayes, 1-925-736-7617;
judy.hayes@ubm.com

EDITOR-IN-CHIEF, EDN WORLDWIDE

Rick Nelson
Test and Measurement, DFX
1-781-869-7970;
richard.nelson@ubm.com

MANAGING EDITOR

Amy Norcross
Contributed technical articles
1-781-869-7971;
amy.norcross@ubm.com

MANAGING EDITOR—NEWS

Suzanne Deffree
Electronic Business, Distribution
1-631-266-3433;
suzanne.deffree@ubm.com

SENIOR TECHNICAL EDITOR

Brian Dipert
*Consumer Electronics,
Multimedia, PCs, Mass Storage*
1-916-548-1225;
brian.dipert@ubm.com

TECHNICAL EDITOR

Margery Conner
*Power Sources, Components,
Green Engineering*
1-805-461-8242;
margery.conner@ubm.com

TECHNICAL EDITOR

Mike Demler
EDA, IC Design and Application
1-408-384-8336;
michael.demler@ubm.com

TECHNICAL EDITOR

Paul Rako
Analog, RF, PCB Design
1-408-745-1994;
paul.rako@ubm.com

DESIGN IDEAS EDITOR

Martin Rowe,
Senior Technical Editor,
Test & Measurement World
edndesignideas@ubm.com

SENIOR ASSOCIATE EDITOR

Frances T Granville, 1-781-869-7969;
frances.granville@ubm.com

ASSOCIATE EDITOR

Jessica MacNeil, 1-781-869-7983;
jessica.macneil@ubm.com

CONSULTING EDITOR

Jim Williams,
Staff Scientist, Linear Technology
edn.editor@ubm.com

CONTRIBUTING TECHNICAL EDITORS

Dan Strassberg,
strassbergedn@att.net
Nicholas Cravotta,
editor@nicholascravotta.com
Robert Cravotta
robert.cravotta@embeddedinsights.com

COLUMNISTS

Howard Johnson, PhD, Signal Consulting
Bonnie Baker, Texas Instruments
Pallab Chatterjee, SiliconMap
Kevin C Craig, PhD, Marquette University

LEAD ART DIRECTOR

Marco Aguilera

ASSOCIATE ART DIRECTOR

Tim Burns

PRODUCTION

Michael Ciardiello,
Director of Premedia Technologies
Jeff Tade,
Production Director
Brian Wu,
Publications Production Manager
Jeff Polman, Derric Treece,
Senior Production Artists
William Baughman, Lucia Corona
Ricardo Esparza,
Production Artists

EDN EUROPE

Graham Prophet, Editor, Reed Publishing
gprophet@reedbusiness.fr

EDN ASIA

Wai-Chun Chen, Group Publisher, Asia
waichun.chen@ubm.com
Kirtimaya Varma, Editor-in-Chief
kirti.varma@ubm.com

EDN CHINA

William Zhang,
Publisher and Editorial Director
william.zhang@ubm.com
Jeff Lu, Executive Editor
jeff.lu@ubm.com

EDN JAPAN

Katsuya Watanabe, Publisher
katsuya.watanabe@ubm.com
Ken Amemoto, Editor-in-Chief
ken.amemoto@ubm.com

EXECUTIVE OFFICERS

Paul Miller,
Chief Executive Officer
Fred Gysi,
Chief Financial Officer
Mike Deering,
Chief Technology Officer
Ron Wall,
Senior Vice President, Publications
Kevin O'Keefe,
Senior Vice President, Events Division
Roger Burg,
Vice President, Operations
Jason Brown,
Vice President, E-media



T&M Atlantic, Inc. tm.atlantic.com www.tmatlantic.com

175 SW 7th Street, Office # 1807,
Miami, FL 33130
Tel.: +1 786 59 777 52, +1 786 220 7693
Tel./Fax: +1 786 369 5192

MEASUREMENT SOLUTIONS



- Oscilloscopes
- Multimeters
- Clamp Meters
- LCR Meters
- Thermometers
- Anemometers
- Light Meters
- Tachometers
- Cable Locator
- Sound Level Meters
- ... and even more!



www.tmatlantic.com

EDN

VOICE OF THE ENGINEER

CUSTOM REPRINTS

HELP YOUR EDITORIAL EXPOSURE STAND OUT.

REPRINTS ARE IDEAL FOR:

- New Product Announcements
- Sales Aid For Your Field Force
- PR Materials & Media Kits
- Direct Mail Enclosures
- Customer & Prospect Communications/Presentations
- Trade Shows/Promotional Events
- Conferences & Speaking Engagements
- Recruitment & Training Packages

1 – 100 Hard Copy Reprints Available!
Visit landing.fosterprinting.com/canoncommunications

For additional information, please contact Foster Printing Service,
the official reprint provider for EDN.

F O S T E R

PRINTING SERVICE

Call 866.879.9144 or
sales@fosterprinting.com



EDN, 33 Hayden Avenue, Lexington, MA 02421. www.edn.com. **Subscription inquiries:** 1-763-746-2792; EDN@kmpsgroup.com. **Address changes:** Send notice promptly to PO Box 47461, Plymouth, MN 55447. Please provide an old mailing label as well as your new address. Allow two months for the change.

UBM Electronics, 11444 W. Olympic Blvd., Los Angeles, CA 90064-1549;
1-310-445-4200; fax: 1-310-445-4299.

Integrated Device Technology – Leader in PCI Express® Solutions

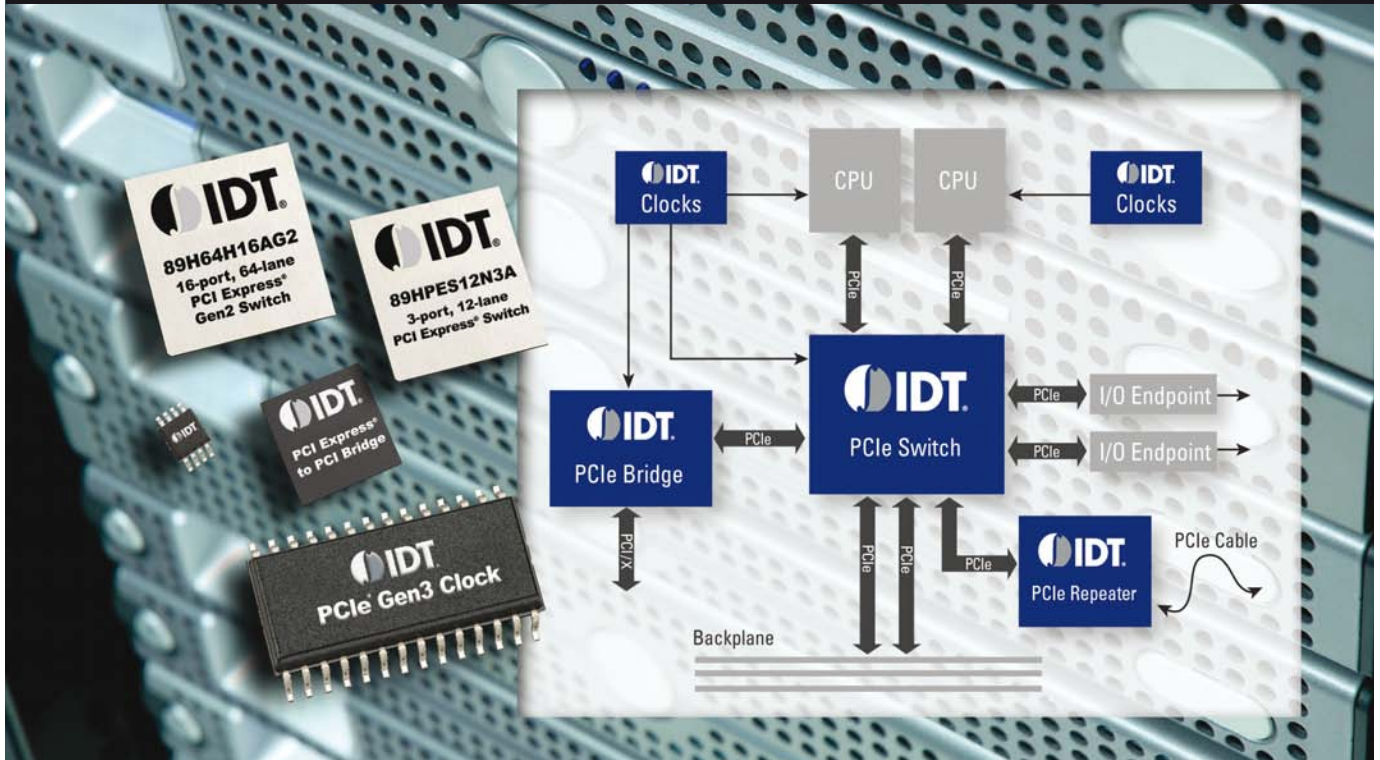

PCI Express Switches

Industry's most comprehensive family of high-performance, scalable PCIe switching solutions

- Gen 1 and Gen 2 Portfolio
- Up to 64 lane and 24 port devices
- Highly flexible port configurations
- Unprecedented 8 non-transparent bridging (NTB) functions to enable multi-root applications

PCI Express Repeaters

5Gbps Gen 2 PCIe Signal Repeaters

- Four and eight channel signal repeaters
- Compensates for cable and PCB trace attenuation and ISI jitter
- Programmable receiver equalization to 30dB and de-emphasis to -8.5dB
- Leading edge power minimization in active and shutdown modes
- No external bias resistors or reference clocks required
- Channel mux mode, demux mode, 1 to 2 channels multicast, and Z-switch function mode

PCI Express Bridges

High performance PCIe bridging to legacy PCI and PCI-X protocols

- Ultra low power version for consumer applications
- Forward mode buffer optimization
- Only PCI Express bridges with Short Term Caching for significant improvement in PCI Read performance
- Pin compatibility with competitive offering for dual sourcing solution

PCI Express Clocking Solutions

Industry's broadest offering of PCIe Gen1, Gen2 and Gen3 clock generation and buffering solutions

- World's First PCI Express Gen3 Family of Timing Devices
- Clock Generators and Synthesizers
- Spread Spectrum Clock Generators
- Fanout Buffers and Muxes
- Jitter Attenuators
- Frequency Translators
- Zero Delay Buffers

IDT
Integrated Device Technology

The Analog and Digital Company™

For more information visit
us online at www.IDT.com

pulse

INNOVATIONS & INNOVATORS

Six-core DSPs enable software selection of 3 or 4G air interfaces

Freescale Semiconductor has announced the next-generation MSC8157 and MSC8158 programmable, broadband, wireless DSPs. The devices offer more than twice the throughput of their MSC8156 predecessor. The DSPs enable SDR (software-defined radio) for base stations, saving OEMs' development costs with field-upgradable code- and pin-compatible products, which reduce operating expenses for wireless carriers. A software switch lets you use the same DSP for multiple technologies or in a multistandard-mode base station.

Freescale manufactured the processors in 45-nm CMOS technology, with 1V core logic, and 2.5, 1.5, and 1.35V I/Os. The MSC8158 targets use in 3G HSPA (high-speed-packet-access) and HSPA+ networks, enabling more efficient and higher-throughput deployments for WCDMA (wideband-code-division/multiple-access) networks.

The MSC8157 handles an array of 3 and 4G wireless standards. For emerging LTE (long-term-evolution) systems with 20-MHz bandwidth, the peak throughput possible takes place at a maximum data rate of 300 Mbps in the downlink and 150 Mbps in the uplink, using a 4x4 array of download MIMO (multiple-input/multiple-output) antennas and a 2x4 array of upload antennas. These features, along with various interference-cancellation schemes, enable the devices to support hundreds of users.

Alternatively, the MSC8157 can support multiple 42-Mbps WCDMA in the downlink and 11-Mbps sectors in the uplink. The devices require no additional ASICs or FPGAs to perform chip-rate acceleration, increasing system performance and decreasing cost and power con-

sumption. The high throughput and flexible chip-rate acceleration, with a capacity of as many as 512 physical channels, allows OEMs to deploy their own variants of chip-rate algorithms.

Mathematical and baseband-intensive tasks, such as MIMO processing, must support as many as eight antennas in 4G TD-LTE (time-domain LTE) systems. The MSC8157 offloads these tasks to an embedded MAPLE (multi-accelerator-platform-engine)-B2 baseband accelerator, freeing the processors' six cores to handle other tasks. The unit also features hardware-accelerated FEC (forward-error correction), FFT/DFT (fast-Fourier-transform/discrete-Fourier-transform), MIMO minimum-mean-square-error, and maximum-likelihood-decoder equalizers.

To address higher capacity and throughput requirements, Freescale added a higher-speed DDR-memory interface, more internal memory, 6G CPRI (common-public-radio-interface) antennas and two serial RapidIO Generation 2 interfaces. For more on this announcement, go to <http://bit.ly/idP1yv>. —by Mike Demler

► **Freescale Semiconductor**, www.freescale.com.

TALKBACK

"It amazes me that companies ... would want to shut out free development activity! All those hackers working up new applications ... and needing [the product] to use them! Silly companies that feel they have to retain control. Heck, even Apple has opened the door ... a little, anyway."

—System/software engineer David Ormand, in *EDN's* Talkback section, at <http://bit.ly/b2lluh>. Add your comments.



The next-generation MSC8157 and MSC8158 programmable, broadband, wireless DSPs offer more than twice the throughput of their predecessor.

Hard-disk drives' burgeoning capacities outshine those of solid-state drives

Some industry observers believe that hard-disk-drive capacities have overshot most computer users' storage needs. As such, other factors beyond the historically dominant metrics of absolute capacity and cost per bit will gain in prominence as selection criteria. Those other factors, such as random-access performance, power consumption, ruggedness, reliability, and operating noise, favor the apparent successor to hard-disk storage: flash-memory-based solid-state drives.

Other industry analysts disagree with that opinion, and hard-disk-drive suppliers provide plenty of ammo to bolster their stance. Consider, for example, some cost-per-bit examples from recent promotional prices. Newegg (www.newegg.com) was selling a Samsung (www.samsung.com) 3.5-in., 1-Tbyte hard drive for \$49.99, along with a Western Digital Corp 2-Tbyte model, for \$99.99. Both of these devices' prices translate to 5 cents per gigabyte. The same retailer was also selling a Toshiba (www.toshiba.com) 2.5-in., 500-Gbyte hard-disk drive for \$49.99, translating to 10 cents per gigabyte. Contrast these hard-disk-drive prices with that of Corsair's 2.5-in., 32-Gbyte solid-state drive,

which Newegg had on sale for \$58.99, translating to \$1.85 per gigabyte.

From an absolute-capacity standpoint, consider recent industry news. Last month, for example, Western Digital unveiled a 3-Tbyte hard drive in a 3.5-in. "bare" configuration that sells for \$239, following up on a \$249.99 external-storage variant with a USB (Universal Serial Bus) 3 interface that it also unveiled last month. At first glance, WD's announcement might seem to be a copycat; after all, Seagate in June launched a 3.5-in., hard-disk-drive-based, 3-Tbyte external drive, whose price is now down to \$199.99 or less. However, Seagate's drive is a five-platter monster reminiscent of Hitachi's four-platter, 1-Tbyte premier in 2007. Conversely, WD's focus was on power consumption, not to mention cost reduction, so it was willing to delay its entry until it could shoehorn the requisite capacity into an industry-leading four-platter configuration.

Hitachi (www.hitachi.com) also in October launched a 750-Gbyte, 2.5-in. hard-disk drive. Again, at initial inspection, you might wonder what the big deal is. Western Digital launched a 1-Tbyte, 2.5-in. hard-disk drive more than a year ago, and

Seagate started shipping a 1.5-Tbyte portable external drive in September. Western Digital's drive, however, is a three-platter, 12-mm design that is thicker than normal and thereby unable to fit into some systems, and Seagate's drive is an even-more-bloated four-platter arrangement. Hitachi's \$129.99 drive matches Seagate's per-platter

The Advanced Format migrates from the 512-byte sector size to the new 4-kbyte sector arrangement.

capacity, but, because it's a two-platter approach, it fits into a conventional 9.5-mm chassis. And it comes in both 5400- and, by early next year, 7200-rpm variants. Effective drive capacity tends to decrease as rotational speeds increase, thereby making Hitachi's high-speed product plans particularly notable from an areal-density standpoint.

Both the Western Digital 3.5-in. drive and the Hitachi 2.5-in. drive use the so-called Advanced Format, which migrates from the traditional 512-byte sector size to the

newer 4-kbyte sector arrangement with resultant stronger ECC (error-correcting circuitry), as a means of more effectively mitigating the degrading effects of raw error rates. Unfortunately, the 4-kbyte sector is inefficient to nonfunctional from both capacity and performance standpoints with legacy operating systems when they directly access the drive. External storage subsystems can invisibly work around some of these incompatibilities, however, by putting an intelligent USB-to-SATA (serial advanced-technology attachment) or FireWire-to-SATA controller between the drive and the computer.

Similarly, Western Digital includes an AHCI (advanced host-controller-interface)-compliant HBA (host-bus adapter) with its 3-Tbyte bare drive. This board's bundling is conceptually no different from Maxtor's approach when it was advocating ATA/133 drives in the absence of native-chip-set support for its proprietary PATA (parallel-ATA) speed, for example, or what some early SATA-drive suppliers did until native-chip-set support for the serial-storage interface reached critical mass. Nonetheless, it's a cost-burdening extra step that I'm sure Western Digital will be happy to dispense with as soon as possible.

Only systems that fully support 48-bit logical-block addressing; contain an EFI (extensible-firmware-interface) BIOS; and run a latest-generation operating system, such as a 64-bit variant of Windows Vista or Windows 7, Mac OS 10.6 Snow Leopard, or a "modified" Linux distribution, can harness the full capacity—more than approximately 2.1 Tbytes—of the Western Digital 3-Tbyte hard-disk drive and its peers. —by Brian Dipert

▶ Western Digital Corp, www.wdc.com.

DILBERT By Scott Adams



MachXO2. DO-IT-ALL DEVICES DEMAND A DO-IT-ALL PLD.

With the MachXO2 PLD family, you now have everything you need to meet your low power, small form factor, high functionality and low price requirements for your next consumer or system design.

Access free reference designs and software, development kits and supporting literature at:

latticesemi.com/machxo2



Applications

- Smart Phone
- Digital Camera
- GPS
- Server
- Router
- Base Station

And more...

Benefits

- Instant-on, non-volatile
- Flexible logic from 256 LUTs to 7,000 LUTs
- Embedded memory up to 240 Kbits
- Ultra low power as low as 19µW
- On-chip user flash memory & I²C, SPI, timer/counter
- Prices starting as low as \$0.75

And more...

Lattice[®]
Semiconductor
Corporation

latticesemi.com/machxo2

VOICES

Avnet's Roy Vallee: back to balance in 2011

The semiconductor industry proved its strength in 2010, outperforming many other segments and recording significant revenue growth estimated at 30 to 35%. But booming demand in many cases met supply shortages as companies reset inventories during the economic aftermath of 2009. Roy Vallee, Avnet Inc's (www.avnet.com) chief executive officer and chairman, spoke to *EDN* about the closing year and the year ahead from his standpoint as an expert on the electronics supply chain. Excerpts of that discussion follow.

What do you think is the key lesson from 2010, a year during which the electronics industry and its engineers spent time recovering from an economic downfall and juggled the electronics supply chain in an attempt to match supply with demand?

A It turned out that real end demand was far stronger than pretty much anybody had anticipated. It turned out to be a whopper of a year. The high-level thought that goes through my head is that, in the 1990s, during the "prebubble" period, the bulk of the demand for the industry was on the business side of things, with products such as IT and communications gear really driving the demand. After the bubble, it seemed as though the consumer sector was the primary end market for growth. In fact, over the five years following the tech bubble, the consumer sector grew to become the No. 1 end market for all electronic components.

As we recover from the recession, for whatever reason, both markets—business spending on various forms

of capital equipment, such as IT and communications—are strong, and people are still buying consumer devices at a fast pace. So I think the amazing story of 2010 is how strong demand was for technology products and how technology once again outperformed the macroeconomy in the way we used to do regularly before the tech bubble.

Have we recovered, or are we still recovering?

A Maybe we have to start with macroeconomics. There I would say that the United States and the rest of the world are in a cyclical economic recovery. It's not as strong as most people would like. It's not as strong as what is typical of a postrecession recovery. But, on a broad basis, there is an economic recovery under way. Then, if you drill down to the industry, my perspective is, yes, we have recovered because Avnet and most of the partners we deal with are back to prerecession levels of revenue. I think that scenario indicates a full recovery.

Could this year have been



as painful as 2009 if inventory had been managed poorly?

A During the recession, the supply chain, pretty much across the board, reacted more dramatically than I have ever seen in my history in this industry. There was a lot of concern about how deep the recession was going to be and how long it was going to last. As a result, people didn't waste any time, and they weren't meek about their actions. In hindsight, now that we found this demand snap-back in 2010, it turns out that we as an industry actually overreacted, allowed inventory and capacity to get too low; then, when demand came back, we ended up with fairly severe shortages.

Leadtimes are still far out in some cases. Do you believe supply and demand will come back into balance in 2011?

A I do. You can see, for example, the significant growth in the semiconductor-capital-expenditure companies, whether it be for the front or the back end. Supply has been ramping up in calendar 2010. Interestingly enough, as we finish the calendar year, seasonal demand will be falling. The combination of ramp-

ing supply and declining seasonal demand will mean that, by the end of the year or early in 2011, we should get back to normal product leadtimes on an average basis. There will always be exceptions to that [prediction], but, broadly speaking, we will be back to normal product leadtimes, perhaps by the end of this quarter or during the first quarter of 2011.

Are we prepared to get back into those normal seasonal trends and product leadtimes next year?

A Generally speaking, I would say yes. I would interject that, to the extent that businesses have created inventories or buffer stocks to support extended product leadtimes and the leadtimes come back to normal, we could experience one or two quarters of slightly below seasonality and then certainly by the second half of 2011 revert to normal seasonality. The experts are all pretty much calling for growth in 2011, maybe slightly below the secular growth rate for the industry over the next three years, but we have to absorb some of this inventory that we built during 2010.

—interview conducted and edited by Suzanne Deffree

Rarely Asked Questions

Strange stories from the call logs of Analog Devices

Oversampling and Undersampling

Q. Why do many modern ADCs have a signal bandwidth much greater than their maximum sampling frequency? Doesn't sampling theory require the signal frequency to be limited to half the sampling frequency? Wouldn't it save power if their input stages had less bandwidth?

A. This has indeed become a common feature in sampling ADCs designed in the last decade or so. The increased bandwidth rarely has much effect on an ADC's power consumption, though, as its input stage usually consists of switched capacitor sampling circuitry. In ADCs that have input buffers, the power consumption of these amplifiers will be roughly proportional to their bandwidth, but as modern amplifier processes continue to evolve, each successive generation delivers more bandwidth for less power.

Sampling Theory¹ states that if a complex signal (made up of components at several different frequencies) is sampled with a sampling clock frequency of less than twice the maximum frequency present in the signal, a phenomenon known as *aliasing* will occur. Sampling with a clock frequency low enough to cause aliasing is known as *undersampling*.

In the early days of sampled data systems the input signal was almost always a base-band signal, with a frequency ranging from dc (or near dc if it was ac coupled) to a cut-off frequency which was usually defined by a low-pass filter (LPF). In such systems aliasing can prevent proper operation and may be a serious problem.

But if the total bandwidth of the signal is less than half the sampling frequency, then aliasing is not a problem—provided the relationship between the sampling



frequency and the range of signal frequencies is correctly defined. Today many sampled data systems work with signals of high frequency, but relatively narrow bandwidth (for example the intermediate frequencies (IFs) of digital radios), and lower frequency clocks. The ADCs for these systems must have wide signal bandwidths but do not need high maximum clock frequencies.

As we saw in an earlier RAO² it is possible to improve the resolution of a sampled data system by increasing the sampling clock rate—the procedure is known as *oversampling*. If the signal bandwidth is small, even though the signal frequency is high, we can build a high-performance system using the ADCs you describe in your question and a clock frequency much higher than the signal bandwidth but much lower than the signal's center frequency. Such a system is simultaneously undersampling and oversampling, unlikely though this may seem at first sight.

¹Often called the Nyquist, or Nyquist-Shannon, Sampling Theory after Harry Nyquist and Claude Shannon who were among the first to develop its theoretical basis.

²RAO 13 - "It may be Greek to you, but sigma delta converters are not really hard to understand."

**To Learn More About
Sampling ADCs**

<http://dn.hotims.com/27763-101>



Contributing Writer
James Bryant has been a European Applications Manager with Analog Devices since 1982. He holds a degree in Physics and Philosophy from the University of Leeds. He is also C.Eng., Eur. Eng., MIEE, and an FBIS. In addition to his passion for engineering, James is a radio ham and holds the call sign G4CLF.

Have a question involving a perplexing or unusual analog problem? Submit your question to:
www.analog.com/askjames

For Analog Devices' Technical Support, Call 800-AnalogD

SPONSORED BY





BY BONNIE BAKER



A good holiday-season project

Which of the bulbs on a Christmas tree is the brightest? If you had the time and desire to answer this question, you could use a single photodiode to determine the brightness of your bulbs. Finding that brightest bulb among the many and the background light would be a laborious task, however, unless you expanded your design task to using two photodiodes. The two photodiodes let you find a light's position by monitoring the difference between their output signals.

If you use three op amps in a differential-photodiode-amp configuration, you will see greater accuracy in proximity and difference (Figure 1).

The configurations of A_1 and A_2 act as traditional current-to-voltage converters or transimpedance amps. A_3 and R_2 form a difference amp, subtracting the output voltages of A_1 and A_2 . In this circuit, the incident light on the photodiode causes current to flow through the diode from cathode to anode. Because the inverting input of A_1 and A_2 has high impedance, the

photodiode's currents flow through the R_1 feedback resistors. The voltage at the inverting input of the amp tracks the voltage at the amp's noninverting input.

Consequently, the amp's outputs change in voltage along with the IR drop across the R_1 resistors. The output voltages of A_1 and A_2 contain both difference and common-mode signals. A_3 rejects the common-mode signal and delivers the differential-voltage signal to the circuit output at V_{OUT} .

The key performance parameters for

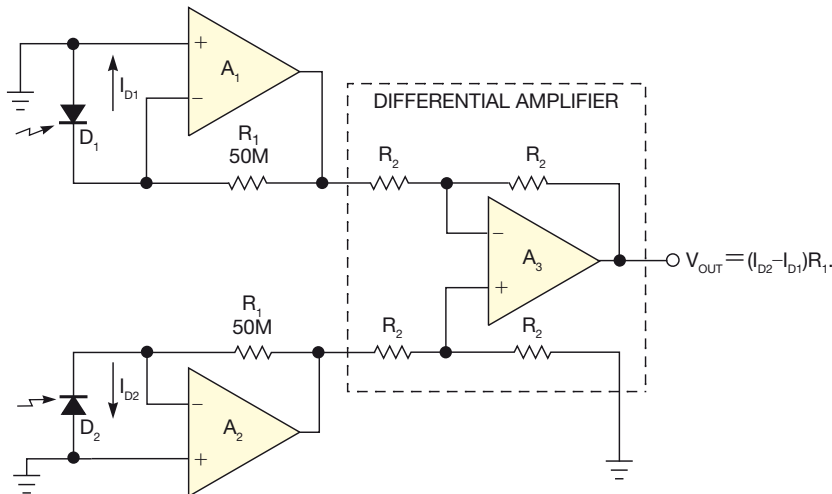

Figure 1 Differential inputs reduce common-mode errors and take the difference of the two photodiodes' signals.

A_1 and A_2 are input capacitance, bias current, offset, noise, and temperature drift. The goal is to select amps in which these parameters are as low as possible. A_1 and A_2 require low-input-current CMOS or FET op amps.

You can implement a differential amp discretely or with an off-the-shelf product. As long as the resistors surrounding A_3 are equal, the dc-transfer function of this circuit is $1V/V$.

If the resistors around A_3 are not equal, a noticeable gain error can occur between the two input signals. You can easily compensate for this type of error by replacing any of the four resistors with a potentiometer. More important, however, this type of mismatch can introduce nonlinearities in the system when the common-mode voltage of the two inputs changes. You define the common-mode voltage of the input signals as $(V_{A1OUT} + V_{A2OUT})/2$. Ideally, the differential amp rejects common-mode-voltage changes. The calculated CMR (common-mode-rejection) error due to resistor mismatches is $100 \times (1 + R_2/R_1) / (\% \text{ of mismatch error})$.

An equal illumination on the two photodiodes makes the output voltage 0V. D_1 and D_2 respond linearly to illumination intensity, which makes the magnitude of the output voltage a direct measurement of the difference between the direct light impinging on D_1 and D_2 .

A single photodiode provides some measure of a light's intensity through the magnitude of the diode's output signal. However, background-light conditions can influence this magnitude, requiring calibrated and impractical measurement conditions. Adding a matched photodiode and monitoring the difference between the two diode outputs removes the equal offsets the two diodes produce. Background light adds only an offset to the photodiode's outputs, and the differential amp removes this effect. **EDN**

Bonnie Baker is a senior applications engineer at Texas Instruments.

Twice the Power Half the Size

New family of high-density power components enables fast, adaptable designs

Example Application

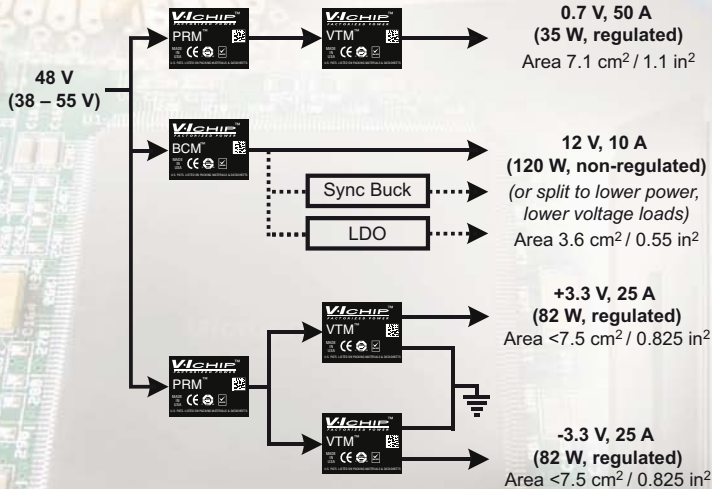

Half-Chip	V _{IN} (V)	V _{OUT} (V)	I _{OUT} (A)	P _{OUT} (W)
BCM	48	12	10	120
PRM	48	5-55	4	200
VTM	48	12	10	135
		6	20	100
		4	25	115
		2	40	88.5
		1.5	50	80



22.0 mm
(0.87 in)

16.5 mm
(0.65 in)

6.73 mm
(0.265 in)

V•I CHIP
FACTORIZED POWER

- 1/32 brick footprint
- Up to 97% efficiency, up to 1300 W/in³
- 200W PRM™ Regulator
- 50A VTM™ Current Multiplier
- 120W BCM™ Bus Converter

Half-size V•I Chip modules increase design flexibility for configurable, high-density, low-profile power system solutions and effectively address lower power applications with better efficiency and state-of-the-art performance.



Visit

www.vicorpower.com/rp/half-chip_edn
for more information
and to order samples online.

All parts available from stock NOW!

Christmas toys: Paper Jamz guitar relies on printed electrodes and connectors

Paper Jamz is a toy electronic guitar that provides a surprisingly good approximation of an electric guitar, relying on three AAA batteries for power and its built-in 1½-in. speaker for sound. Both its name and its low price of \$25 hint that the guitar relies on printed-on electrodes and signal traces for its construction. It can serve as a case study in how sophisticated products can result from a powerful microcontroller and some capacitive-touch sensing inputs.

You don't really need pressure to select a chord. With capacitive-touch sensing, just the presence of your finger is all it takes to select the chord of the mode or activate playing the strings. Capacitance exists between an electrode and any surrounding conductive material. The human body, although less conductive than a piece of copper wire, is still an adequate conductor. When a finger, for example, comes close to an electrode, the capacitance increases. A handy microcontroller senses that increase and serves as a triggering event. The sensing electrode is a grid of printed conductive traces that lie below the surface layer of plastic film.

A plastic-film tab with printed conductive traces wraps over from the back side and serves as a connector. The top of the neck cover secures the tab in place, clamping it onto the 1½x2-in. PCB (printed-circuit board).

The whitish square on the far left side of the PCB is a flexible membrane that forms a cheap switch: The black dot is a bit of conductive material. Pressing it causes it to contact and complete a circuit between the PCB traces below it. It's accessible only before the manufacturer seals up the guitar, so it's probably a go/no-go test run to make sure the toy passes at least a simple end-of-assembly test. An eight-pin SOIC CE0030B chip from Chippower is a 1W, fully differential audio power amplifier with internal feedback resistors. The guts of the board seem to reside under a 1/16-in.-thick black blob of epoxy—too thin for a packaged part. This type of packaging, COB (chip on board), or blob top, is likely the microcontroller. You can usually purchase less expensive chips as bare die and wire-bond them onto the PCB. Even allowing for the cost of wire bonding, it's still a cheaper manufacturing process.

The small yellow device on the power output from the AAA battery compartment is probably a PTC (positive-thermal-coefficient) over-current- and overtemperature-protection circuit to prevent short circuits and overheating of both the battery assembly and the circuit.

At approximately 30 in. long, Paper Jamz is smaller than a typical electric guitar; considering its target audience, however, this size is understandable. Despite its name, it's not paper. Instead, it's a plastic, guitar-shaped shell that appears to be screen-printed with artwork including strings, a sound hole, frets, and volume knobs. It has three play modes. In freestyle mode, you refer to a chord chart that shows which frets to press for a chord. For major chords, pressing either one or two frets makes a chord. This use model is a far cry from using a real guitar, with which you must fret several strings at once. Paper Jamz is much simpler and allows young players to imitate rock musicians even if their fingers' dexterity isn't up to individual-string fretting.

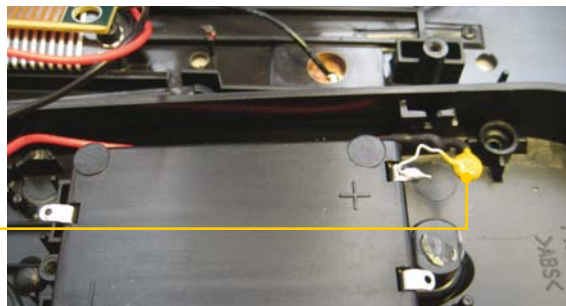
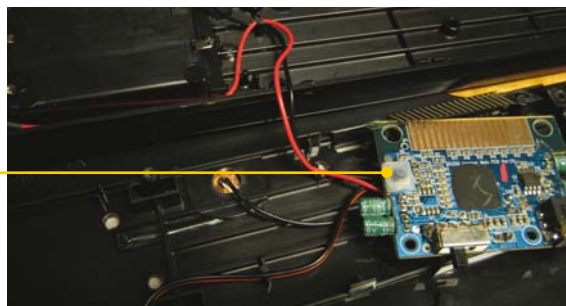
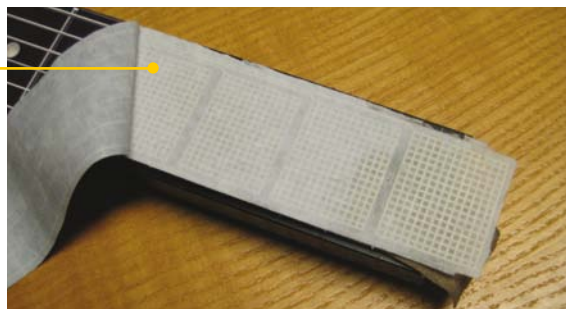



NEW
fully-assembled
turnkey solutions

Run, drive, or fly
your Simulink
design in real time,
using Rapid Prototyping
or Hardware-in-the-Loop
simulations on low-cost
PC-based hardware.
xPC Target provides a
library of device drivers,
a real-time kernel, and an
interface for monitoring,
parameter tuning, and
data logging. It supports
a full range of standard
IO modules, protocols,
and target computers.

MATLAB®
& SIMULINK®



Find it at

mathworks.com/accelerate

datasheet
video example
trial request



**RUN MODELS
IN REAL TIME**

with

Simulink
and xPC Target™

 **MathWorks®**
Accelerating the pace of engineering and science

MECHATRONICS IN DESIGN

FRESH IDEAS ON INTEGRATING
MECHANICAL SYSTEMS,
ELECTRONICS, CONTROL SYSTEMS,
AND SOFTWARE IN DESIGN

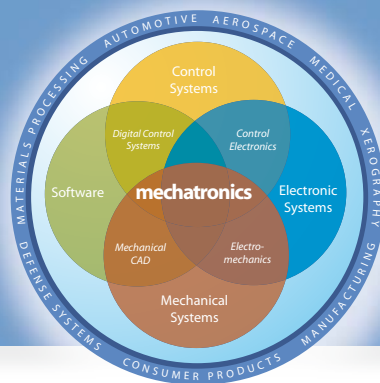

PLM and mechatronics

Product-life-cycle management enables the mechatronics-design philosophy.

Mechatronics is a design philosophy that emphasizes multidisciplinary, model-based communication, collaboration, and integration from the start. Sustainability has further challenged mechatronics to transform itself into a closed-loop, cradle-to-cradle design approach. PLM (product-life-cycle management) is a process of managing the entire engineering life cycle of a product, along with the software tools to synchronize information. Just as in mechatronics, we now view this life cycle as one that stretches from conception; through design and manufacturing; to service, disposal, and recycling. Just as a key element in mechatronics is human-centered design, PLM is becoming more human-centered, in addition to being information-centered.

Recently, I gave a speech about mechatronics and innovation at the Product Lifecycle Management 2010 Conference in Detroit. PLM is certainly not new, having made its debut 25 years ago, but it was my first exposure to the world of PLM, and major companies from many industries were

By creating one database that serves as the central source of information, PLM reduces rework due to confusion over data from multiple databases.

there. With the need to manage increasingly complex designs, along with the imperatives for energy-efficient, sustainable, and environmentally responsible design, PLM is clearly a subject of great interest worldwide.

How are mechatronics and PLM related? Does PLM take over when the mechatronics effort ends, or are they becoming integrated so that both become better? To better understand the world of PLM today and in the future, I spent considerable time with John Bayless, the director of strategy and program management for Mercury Marine and the practice director for Mercury Marine PLM Services, a PLM-consulting business within Mercury Marine. Bayless is a graduate of the US Naval Academy (Annapolis, MD), who served as a US Navy fighter pilot. He holds a master's degree in business administration from the University of Michigan's Ross School of Business (Ann Arbor, MI).

In Bayless' view, the link between a mechatronics approach

and PLM is the need for collaboration during product development. A mechatronics approach calls for a cross-functional team to come together in a way that encourages specialists to make mutual design adjustments to reach a better final design. The execution of a mechatronics approach creates a need for PLM.

Part of mechatronics' need for PLM stems from the difficulty specialists, often in disparate locations, have coming together early and often enough to collaborate on the latest design information. A PLM system eases collaboration by connecting engineers and cross-functional team members, such as manufacturing, procurement, and marketing, almost in real time. For example, by

creating one database that serves as the central source of information, PLM reduces rework due to confusion over data from multiple databases. When engineers use this approach to its fullest potential, PLM saves time—time that they could better use creating innovations for new products.

From my discussion with Bayless, I learned that the scope of PLM implementation varies by company. For example, some Mercury PLM Services clients are considering their first investment in PLM and are looking for reliable information. Other clients use PLM only to store CAD data but are interested in deploying the tools in more value-added ways across the enterprise. Mercury PLM Services provides best practices that bring PLM benefits to the organization, not just one discipline, making it ideal for mechatronics.

Communication, collaboration, and integration are the key attributes of mechatronics design that lead to innovation. PLM—managing all the information from the start of the design to the eventual disassembling and recycling of the product—can facilitate that process. We must first, however, define and widely embrace mechatronics design for the organization. Each individual's ownership of the process, not just a consensus, is essential to reaping the full benefits of PLM. **EDN**



Kevin C. Craig, PhD, is the Robert C Greenheck chair in engineering design and a professor of mechanical engineering, College of Engineering, Marquette University. For more mechatronics news, visit mechatronicszone.com.

“How can I tell if a power supply is reliable?”



There's an indicator on the front.

It says “Agilent.” With a typical MTBF of 40,000 hours, over half-a-century of experience, and with more than 250 models to choose from, Agilent's power supplies are the ones you can count on. In fact the array of our power supplies is so extensive, it wouldn't fit on this page. For clean, low-noise, programmable power to countless DUTs, there's an Agilent power supply with your name on it. Actually, it's our name on it, but you know what we mean.

© 2010 Agilent Technologies, Inc.

**Agilent and our
Distributor Network**
*Right Instrument.
Right Expertise.
Delivered Right Now.*

**Buy from an
Authorized Distributor**
www.agilent.com/find/distributors

**For free measurement tips and the
Agilent Power Products brochure go to**
www.agilent.com/find/power_tips



Agilent Technologies

CONVENTIONAL LCDs' INDUSTRY DOMINANCE MIGHT SEEM INSURMOUNTABLE, BUT, NOT TOO LONG AGO, PEOPLE WERE SAYING THE SAME THINGS ABOUT CRTs. UPSTART REVOLUTIONARY ALTERNATIVES ASPIRE TO ASCEND TO THE THRONE, BUT LCDs INTEND TO RETAIN THE CROWN.

DISPLAY-TECHNOLOGY ADVANCEMENTS: CHANGE IS THE ONLY CONSTANT

BY BRIAN DIPERT • SENIOR TECHNICAL EDITOR



Repeatedly predicted and repeatedly delayed on many occasions, the transition from CRTs (cathode-ray tubes) to LCDs (liquid-crystal displays) has finally occurred, even in cost-sensitive emerging markets and across dominant application segments: computer monitors and televisions. Small-format LCDs also find wide use in diverse portable electronics devices, along with some digital projectors. However, LCDs have lingering imperfections, including low refresh rates and lengthy response times, constrained viewing angles, high power consumption and cost, and poor perceptibility in direct sunlight and other high-ambient-light conditions. As a result, manufacturers are always looking for ways to eliminate these imperfections in this all-important, evolving technology.

COMPOSITE IMAGE BY TIM BURNS. THERMOMETER: KTSIMAGE/ISTOCKPHOTO.COM; BACKGROUND: MERRYMOONMAY/ISTOCKPHOTO.COM

Some developers focus their efforts on making incremental improvements to a “vanilla” LCD foundation. Other cases warrant a more revolutionary transition—to OLEDs (organic light-emitting diodes) for an ultrasvelte consumer-electronics device, for example, or to an “electronic-paper” display for a digital reader. Historical trends make it clear that there’s no one-size-fits-all display approach for all applications, no matter how much the resultant volume cost and, therefore, price efficiencies might favor such consolidation. They also make it clear that there’s no shortage of creativity fueling ongoing technological innovation—both in the near term to provide credible alternatives to currently dominant approaches and in the long term to capture the dominance prize.

SUBPIXEL VARIATION

Figure 1 shows the basic operational concepts of an LCD. Normally, the perpendicular polarization orientations of two parallel polarizer layers block transmission of ambient-environment-generated light that reflects off a mirrored back panel, self-illumination by a backlight, or both, leading to an array of perceived-black pixels. However, ITO (indium-tin oxide), the same increasingly rare material that touchscreens use, delivers a sufficiently strong applied electric field to alter the intermediary liquid crystal’s modulation properties (references 1 and 2). This alteration translates to light transmission of varying intensity. Initially popular passive-matrix displays individually and, therefore, sequentially accessed each row-and-column rudimentary circuit

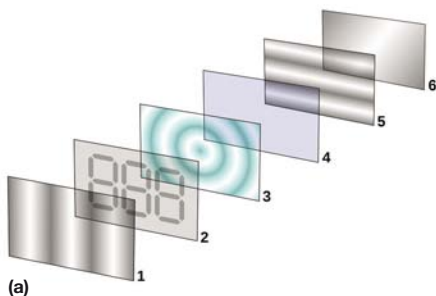

AT A GLANCE

- ▣ Various LCD (liquid-crystal-display)-pixel-structure alternatives deliver varying expense-versus-quality results.
- ▣ Striving for optimal cost, power consumption, color gamut, and other attributes, fresh approaches are challenging the dominant RGB (red/green/blue)-subpixel-triplet arrangement.
- ▣ High pixel densities are largely the domain of mobile displays, which, unlike their bigger siblings, have also largely retained the legacy 4-to-3-aspect-ratio pixel arrangement.
- ▣ Backlights come in diverse variants; with OLEDs (organic light-emitting diodes), they’re unnecessary.
- ▣ Full-color, fast-refresh displays represented overkill for first-generation e-book readers, but their descendants are increasingly dissatisfied with molasses-slow monochrome screens.

intersection, thereby requiring each pixel to hold its state between refreshes and translating into slow response, low contrast ratios, and other shortcomings that became worse as resolutions and screen sizes increased.

The active-matrix LCD successor relies on a matrix of TFTs (thin-film transistors), with at least one transistor devoted to each pixel, thereby allowing for precise column-line-to-pixel

correlation. After the display controller activates a row line, it drives the relevant pixels’ specific voltages on the column lines. A display-refresh operation sequentially activates all of the row lines. With the now-dominant TN (twisted-nematic) LCD, the liquid-crystal elements twist to varying degrees in response to a varying applied voltage, constructively or destructively interacting with the polarizing filters’ effects to pass varying amounts of light. Precise electric-field control combines with refresh-pattern-modulation techniques to enable the generation of any per-pixel gray-scale value.

IPS (in-phase switching) LCDs emerged in response to display users’ requests for improved viewing angles, deeper black levels, and other enhancements. The IPS LCD horizontally aligns the liquid-crystal cells with subsequent application of the per-pixel electrical field through the crystals’ ends, thereby requiring two transistors per pixel—more costly than TN’s approach. Historically, at least until the unveiling of LG Display’s Enhanced IPS approach, the incremental per-pixel circuitry also negatively affected light-transmission efficiency, thereby necessitating brighter and more power-hungry backlights to compensate.

Speaking of LG, IPS historically found use only in high-end professional displays and other application niches that could tolerate the technology’s inherently higher cost. However, Apple adopted Enhanced IPS LCDs in the company’s latest-generation Cinema Display, iMacs, iPads, and iPhone 4. This adoption should spur price-cutting high-production volumes that other potential customers can also beneficially leverage

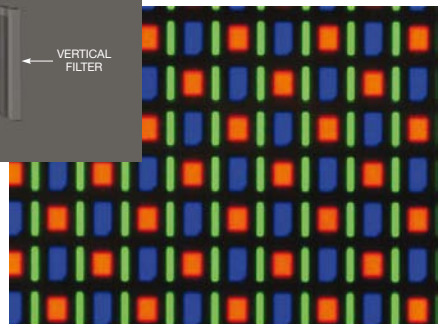
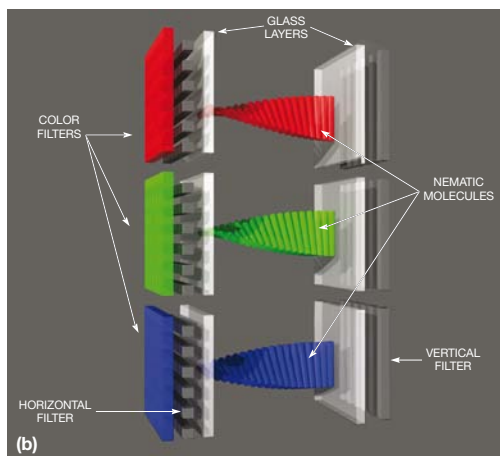

Figure 1 The conventional-LCD-pixel structure is easy to understand (a), but minor structure variations produce major differences in results. An RGB subpixel triplet is the most common means of delivering color to the eye (b), but plenty of alternative approaches, such as this PenTile arrangement, are also possible (c).

(Figure 2). An intermediary approach, the VA (vertical-alignment) LCD, offers an approximation of the TN-to-IPS quality improvements. However, VA LCDs, which come in multidomain and patterned variants, require only one transistor per pixel. As such, they have lower per-pixel costs than IPS alternatives.

The varying twist and refresh-modulation techniques enable an LCD to dynamically calibrate the luminance intensity of each pixel, thereby generating pure black, pure white, and shades of gray between these range extremes. Subpixels are the keys to an LCD's ability to generate color from a white-backlight illumination source. Each of the

307,200 pixels in a conventional VGA (video-graphics-array)-resolution panel, for example, comprises three close-proximity subpixels, each with an associated red, blue, or green filter that enables only the relevant portion of the visible-light spectrum to pass through it. Selective control of the subpixels creates the illusion of a pure-color pixel. Dithering further fools the eye and brain, thereby expanding the perceived-color palette. Subpixels have other uses, as well. Microsoft's ClearType rendering technology, for example, sacrifices color accuracy to enhance the perceived sharpness of displayed text (Reference 3).

The RGB (red/green/blue) subpixel pattern is the dominant but by no means the only approach in use. Nuovoyance (formerly, Clairvoyante before its 2008 acquisition by Samsung, of which it is now an independent subsidiary) has developed a series of alter-

**RED/GREEN/BLUE/
WHITE MAXIMIZES
DISPLAY BRIGHT-
NESS FOR A GIVEN
AMOUNT OF POWER
CONSUMPTION.**

native arrangements that the company brands PenTile for various target applications and attributes. The initial approach mimics the cone-cell proportions in the human eye. The quincunx-unit cell comprises two red subpixels, two green subpixels, and one centrally located blue subpixel. Another pattern, RGBW (red/green/blue/white), maximizes display brightness for a given amount of power consumption and is reminiscent of the panchromatic image-sensor pattern that Eastman Kodak introduced in 2007.

Kodak's legendary Bayer-pattern image sensor, which takes its name from Bryce E Bayer, PhD, who patented it in 1976, has a Nuovoyance-equivalent RGBG (red/green/blue/green)-display pattern; both arrangements exploit the fact that the human visual system is most sensitive to green-spectrum information. The RGBG PenTile approach encompasses one-third fewer subpixels



ADSANTEC

Advanced Science and Novel Technology Co., Inc.
27 Via Porto Grande Rancho Palos Verdes, CA 90275
Phone: +1-310-377-6029 | Fax: +1-310-377-9940

ULTRA HIGH-SPEED SiGe MIXED SIGNAL INTEGRATED CIRCUITS

Variety of broadband delay line ICs that feature precise linear analog delay control, output amplitude adjustment, temperature compensation, and low power consumption. They can process data / clock signals from DC up to 40Gb/s / 32GHz. The delay lines come in either standard 24-pin plastic QFN or custom high performance 24-pin metal ceramic packages.

Several SerDes solutions including a digital broadband 16:1/1:16 MUX/DMUX, operating from DC up to 16 GHz; 16:1 MUX CMU and 1:16 CDR DMUX that are Telcordia compliant, operating at 12.5Gb/s, housed separately in standard 100-pin QFN packages. Other ASICs are digital 2:1 and 1:2 SerDes pair running at 50Gb/s; variety of variable output amplitude limiting amplifiers; Linear TIAs and dual TIAs; Clock/Data Splitters; Frequency Dividers and Glue Logic Components.

Clock and data recovery (CDR) monolithic IC, operating from 22Gb/s up to 32Gb/s that meet all SONET specification requirements. CDRs can process either RZ or NRZ input data signals. All CDRs are packaged in a custom, high performance, hermetically sealed, 64-pin metal ceramic package.



ASNT5175-PQC



ASNT2011-PQA



ASNT2110-KMF

See our entire product line at
WWW.ADSANTEC.COM/PRODUCTS
 Call to order (310) 803 - 9284

ADSANTEC is an industry leader in providing high frequency mixed signal IC products for the test/measurement and optical transport networking equipment markets.



Figure 2 Apple's latest-generation Cinema Display (a), iMacs (b), iPad (c), and iPhone 4 (d) all harness IPS LCDs, making it increasingly likely that this formerly "boutique" technology will achieve mainstream adoption.

than that of a traditional RGB pattern, but primary inventor Candice H Brown Elliott claims that it delivers equivalent perceived display resolution. The RGBG PenTile pattern currently finds use in Samsung's OLED panels for mobile phones, digital cameras, and other consumer-electronics devices.

Sharp is the only remaining notable Japanese LCD manufacturer, and the company is striving to technically differentiate itself from South Korean, Taiwanese, and Chinese competitors to remain relevant in the future. At the 2009 SID (Society for Information Display) show in San Antonio, TX, the company showed prototype LCDs employing a five-subpixel pattern incorporating not only traditional red, green, and blue additive colors but also the cyan and magenta subset of the subtractive-color palette. Six months later, at the January 2010 CES (Consumer Electronics Show), Sharp unveiled a series of Quattron RGBY (red/green/blue/yellow)-subpixel-pattern-based TVs ranging in screen size from 40 to 68 in., some of which are now in production, with others to follow next year.

The company's promotional materials dish up no shortage of hyperbole, claiming that this subpixel combination delivers more than 1 trillion distinct colors versus conventional RGB's billions, "faithfully rendering nearly all

colors that can be discerned with the unaided human eye" and delivering "more sparkling golds, Caribbean blues, and sunflower yellows" (Reference 4). Sharp conveniently fails to mention, however, that Panasonic in the 1970s unveiled conceptually similar Quattron CRT TVs, which met with an underwhelming market embrace and which the company quickly discontinued. Sharp also doesn't seemingly have a compelling answer to the question of why an RGBY display enhances content that gear with only conventional RGB-subpixel cognizance originally captured and processed. However, at least one other company seemingly feels that Sharp is onto something: Apple recently filed patents that one-up Quattron by advocating a pure CMYK (cyan/magenta/yellow/black) subtractive-display approach (Reference 5).

RESOLUTIONS, ORIENTATIONS

Modern flat-panel televisions, regardless of their screen sizes, tend to comprehend a native resolution no finer-detailed than 1080p—that is, 1920×1080 pixels in a wide-screen orientation. This upper-end resolution cap makes them easier to manufacture and, therefore, higher yielding and less expensive, and the suppliers rationalize the pixel-count ceiling by pointing out that commercially available video content is 1080p in maximum resolution.

Granted, consumers might prefer to view higher-quality versions of the still images their high-resolution digital cameras capture, but there's insufficient demand for the feature to justify its development and deployment by TV manufacturers and their

panel partners.

Samsung this year voiced long-term concern about the resolution cap at a meeting in South Korea. As available screen sizes continue to increase and at close-enough viewing distances, observers will increasingly be likely to discern discrete pixels and the boundaries between them—an undesirable capability. Movie theaters currently project digital content at 2 and 4K resolutions—approximately 2048 horizontal pixels and approximately 4096 horizontal pixels, respectively. No consumer-oriented physical-media format currently supports these resolutions, however. Downloadable and streamed media are more flexible (Reference 6). Similarly, NHK, among other companies, has for several years now at CES demonstrated compelling UHDTV (ultra-high-definition digital television), which NHK brands SHV (superhigh vision), but a broad market rollout remains elusive.

You might believe that computer displays would be more amenable to very-high-resolution pixel configurations, and you'd be right, but probably not to the extent that you might think. Granted, computer monitors' close-proximity viewing arrangements encourage high pixel resolutions and, therefore, fine pixel pitch. Computer monitors have smaller screen formats than do TVs, somewhat counterbalancing these attributes. And the content, including photographs, text, and the like, that users view on these monitors is more amenable to fine-detail capabilities. But the resolution restrictions of legacy analog VGA, digital single-channel DVI (digital-visual-interface), and HDMI (high-definition-multimedia-interface) connections have to some degree limited display-quality evolution—a limitation that DisplayPort has had limited success in alleviating (Reference 7).

The decreased manufacturing complexity, increased yield, and, therefore, lower cost and higher supply of lower-

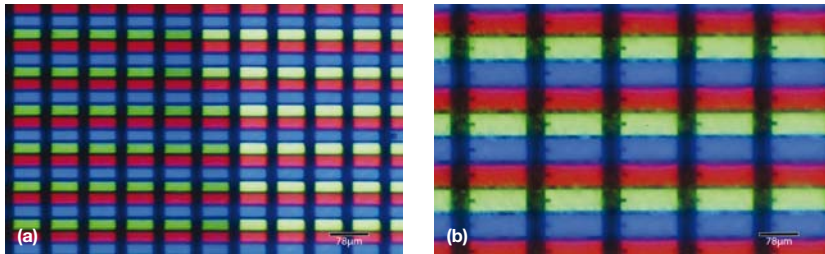

Figure 3 The high-resolution Retina display (a) squeezes four times the pixels into the same screen real estate as its conventional LCD predecessor (b).

resolution displays at a given screen size also factor into the price-versus-quality trade-off that has placed higher-resolution alternatives into high-profit-margin but low-volume market niches. You also cannot ignore the dots-per-inch constraints of legacy operating systems and programs. Even with a leading-edge, dot-per-inch-flexible operating system, such as Microsoft's Windows 7, a legacy application that assumes a traditional 72-dpi density produces unacceptably small or, when interpolated, fuzzy fonts and graphical elements when output to a higher-dot-per-inch display.

Fortunately, such legacy limitations are not factors in many modern mobile operating systems and applications. With the ultrasmall displays in mobile phones, multimedia players, cameras,

and the like, system hardware and software can effectively harness a higher dot-per-inch density, making for a notable improvement in user-perceived quality. With the latest-generation iPhone 4, for example, Apple worked with LG Display to implement Apple's Retina LCD. Retina not only employs IPS rather than the conventional LCD technology that the previous-generation iPhone 3GS uses but also touts a 960×640-pixel resolution, translating to 78 micron-wide pixels that deliver a 326-ppi (pixel-per-inch) density, versus 480×320 pixels with the iPhone 3GS in the same 3.5-in.-diagonal size (**Figure 3**). More recently, Sharp unveiled a matching-specification display in the company's ISO3 Android-based mobile phone. At October's CEATEC (Combined Exhibition of Advanced Tech-

nologies) in Japan, Hitachi showed off a 302-ppi display, albeit a 6.6-in.-diagonal screen—nearly twice the size of the Retina display in the iPhone 4. Also in October, the Casio/Toppan joint venture, Ortustech, announced a 4.8-in.-diagonal display with a 1920×1080-pixel resolution, translating to a 458-ppi density.

Although pixel density is one of several key determinants of the quality of the content you view, aspect ratio—that is, the number of horizontally and vertically arranged pixels—defines how much of the content you can see on the screen at once. The growing popularity of wide-screen-formatted TV programs, movies, and other video content has driven the inexorable migration in recent years of TVs and computer displays to the now-dominant 16-to-9 and similar ratio dimensions. Computer-game players, stock traders, and other power users may even stack multiple displays side by side to further increase the configuration's horizontal real estate. However, plenty of computer users who predominantly view conventional content while Web browsing, writing, creating spreadsheets and performing calculations using them, and doing similar activities bemoan the perceived “lost” vertical resolution of a wide-screen dis-

PLASMA LIVES TO FIGHT ANOTHER DAY; SED FADES AWAY

In early 2005, when *EDN* last covered direct-view displays in detail, I was admittedly skeptical about plasma technology's ongoing relevance (**Reference A**). Its cost advantages were yielding both to LCD (liquid-crystal-display) manufacturers' aggressive ramp-ups in glass dimensions and to consumers' cool embrace of huge screens. Plasma-display manufacturers were exiting the business, and the LCD-supplier list was growing. Tack on the fact that plasma displays have worse power-consumption performance and weigh more than LCDs and that

they have a gas-pressure-induced intolerance of operation at high elevations, and many industry observers were ready to write the technology's obituary.

With a nod to Mark Twain, the report of plasma's death was an exaggeration, at least for the short term. The 3-D content in homes, an emerging trend, is at least temporarily reinvigorating plasma technology, thanks to its nearly instantaneous pixel-refresh rate, which eliminates the “ghosting,” flickering, and other artifacts currently plaguing LCDs. The remaining

plasma-display manufacturers shouldn't rest on their laurels, however. The degree of consumer embrace of 3-D displays is not yet determined, and LCD suppliers are moving quickly to erase any advantages of plasma in this arena.

Although plasma strives onward, a promising display technology nearly six years ago, SED (surface-conduction electron-emitter display), has fallen by the wayside. Its primary backer, the Canon/Toshiba joint venture, once touted it as the modernized successor to the CRT (cathode-ray

tube). However, implementation costs were higher than the companies had anticipated, and development delays were lengthier than they had forecast. Those problems, along with the fact that Applied Nanotech brought a distracting intellectual-property lawsuit and that the competitive LCD juggernaut was improving, ultimately led to the demise of the SED.

REFERENCE

A Dipert, Brian, “Master of some: direct-view-display technology,” *EDN*, March 5, 2005, <http://bit.ly/aKezqy>.

Introducing ...

SR1 Audio Analyzer

- **-110 dB THD + N** (1 kHz, 2 V, 22 kHz BW)
- **± 0.008 dB flatness**
- **200 kHz system bandwidth**
- **24-bit / 192 kHz digital audio**
- **<600 ps residual jitter**
- **Cross-domain analysis**

SR1 ... \$6900 (U.S. list)

Introducing SR1 Dual-Domain Audio Analyzer
— AP 2700 class performance at \$6900.

SR1's outstanding specifications and rich suite of measurements make it ideal for analog, digital and cross-domain audio signal analysis.

Standard measurements include Level, THD + N, Harmonic Distortion, IMD, FFT, Frequency Response, Multi-Tone, Crosstalk, Histogram, Jitter Amplitude & Spectrum, and more. Hardware options include a digital audio carrier digitizer with full-color eye diagrams and carrier spectra, multi-channel I/O switchers, and an atomic rubidium system clock.

SR1 offers uncompromised performance at a fraction of the price of the competition.

Call us or visit our web site for further details.

thinkSRS.com

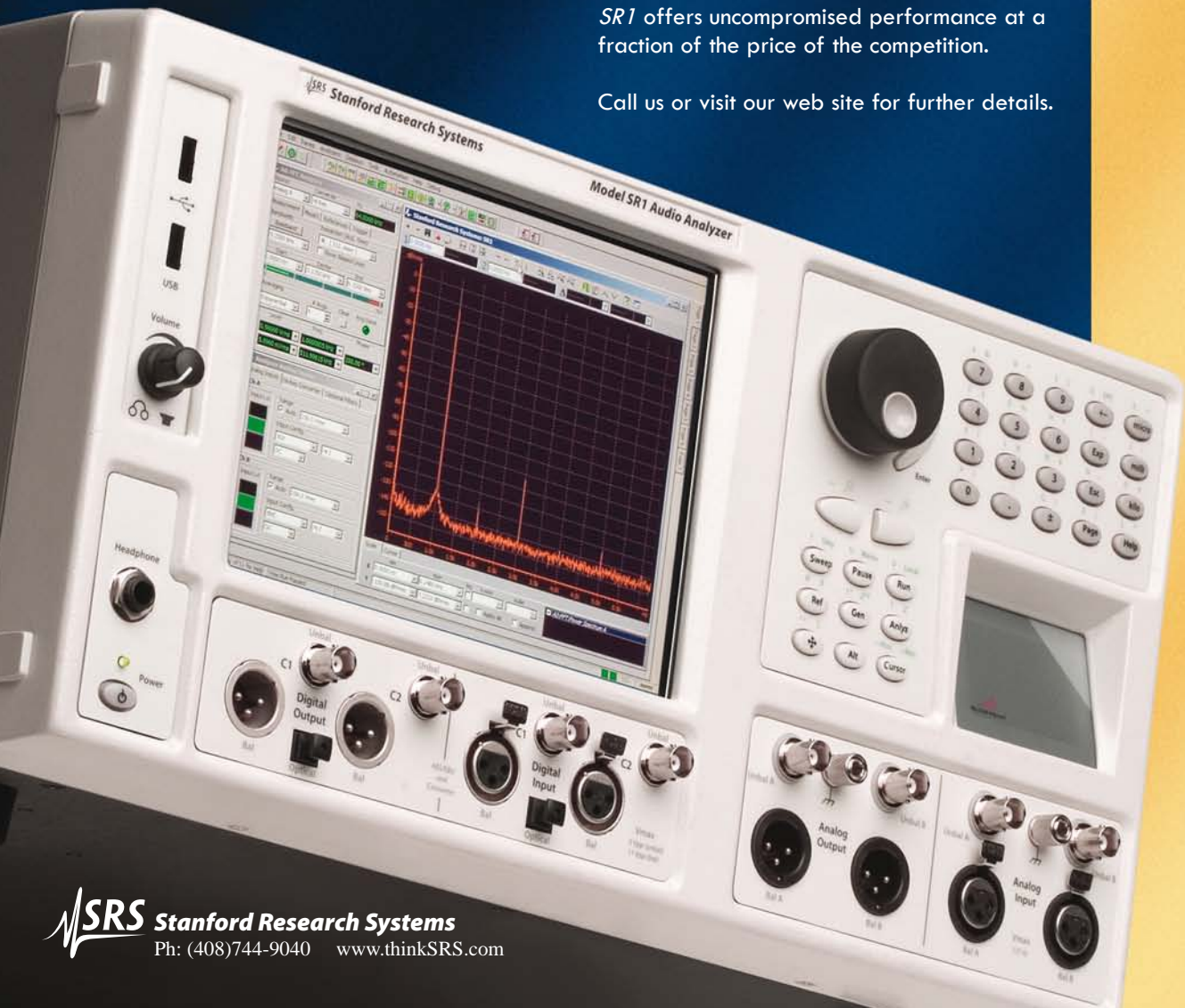

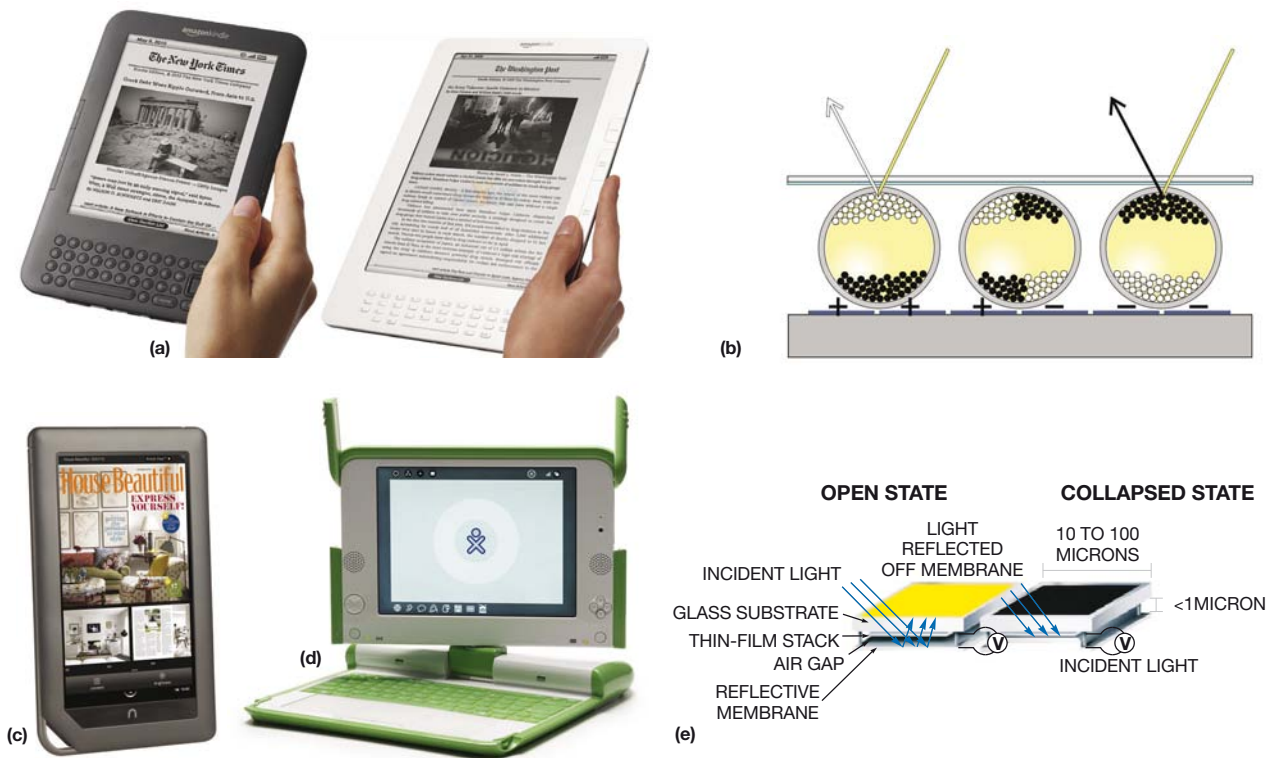

Figure 4 Amazon's latest Kindle and Kindle 3 e-book readers (a) harness E Ink's second-generation, higher-contrast Pearl bistable display (b). Barnes & Noble has taken a more colorful, albeit more costly, LCD-inclusive tack with its latest Nook device (c), and the OLPC provided the foundation on which Pixel Qi aspires to build a successful display business (d). Meanwhile, Qualcomm leveraged butterfly-wing biomimicry in coming up with its Mirasol MEMS-based IMOD approach (e).

play versus the predecessor's 4-to-3 aspect ratio (references 8 and 9).

On the other hand, mobile electronics' displays have at least to date largely bucked the wide-screen-conversion trend that has marked their larger-format brethren. In part, this continued reliance on the legacy aspect ratio is due to the fact that a system with a portrait-oriented, 4-to-3-aspect-ratio display tends to fit better into a user's hand. It's also partly due to the fact that most of the content users access on such systems continues to be best viewed on a screen other than a wide one. Apple, for example, received no shortage of unwarranted criticism from early reviewers of the iPad, who, in focusing on video-playback applications, overlooked the fact that electronic-publication-reader programs mimic the printed page that has an approximate 4-to-3 aspect ratio in both single-portrait and dual-page-landscape configurations.

BACKLIGHT OPTIONS

Historically, nonreflective LCDs have largely leveraged CCFL (cold-

cathode-fluorescent-lamp) backlights, whose dominant attributes included low cost and a diverse supplier base. However, they're less than ideal in numerous other respects, including inconsistent illumination among lamps, despite intermediary diffuser use; from power-up to stable subsequent operation; and as they age. They also have limited operating life before hard failure, notable incremental effects on both display thickness and display power consumption, environmentally damaging or costly disposal characteristics, and low display ruggedness and reliability. In addition, they cannot deliver deep blacks because the CCFL backlight is always on, and some amount of light leaks through the polarizing filters and to the viewer's eyes.

Some niche situations have also employed incandescent light bulbs, ELPs (electroluminescent panels), and HCFLs (hot-cathode fluorescent lamps) as backlights, and all have unique combinations of strengths and weaknesses, but LEDs appear to be the emergent widespread CCFL-backlight successor. Initially too expensive to use in any

but the smallest display-real-estate settings, they've rapidly decreased in price in pace with their burgeoning adoption in diverse applications. As such, now that cost is increasingly not prohibitive, they neatly address CCFLs' shortcomings. Design engineers love LED backlights' advantages, and marketers leverage them by giving their products misleading monikers. For example, Samsung in mid-2009 began—and continues—to promote "LED TVs," despite complaints from Britain's Advertising Standards Authority and other consumer-advocacy groups (Reference 10). Unfortunately, other manufacturers have followed suit.

The first-generation LED-backlight configuration, which remains in widespread use, is reminiscent of its CCFL predecessor: multiple white LEDs spread across the screen with a diffuser, or light guide. A reflective layer behind the LED array boosts the backlight efficiency by redirecting toward the user emitted light that might otherwise go to waste. Elementary LED-backlight designs drive all of the available LED elements to the same intensity. So-called

local-dimming approaches take the architecture to the next logical step. By individually controlling the intensity of each LED element, they boost the display's effective contrast ratio at the trade-off of increased required processing intelligence and therefore cost built into the display.

An increased color gamut is the key focus of the next increment in LED evolution, which harnesses the fact that LEDs come not only in white but also in red, green, and blue variants. By individually controlling the intensity of each sub-LED within a three-color cluster, a display manufacturer can positively affect not only contrast ratio but also the palette and accuracy of visible colors the LCD outputs. Conversely, edge-lit LED arrangements focus on thickness and, to some degree, backlight cost. In this case, as the name suggests, the LED arrays reside on two or all four border spans of the display, with light guides spreading their illumination across the back panel. Localized contrast and color control are impossible with such a configuration, but,

in exchange, the display can be both slightly thinner and potentially cheaper than its backlit counterpart.

Any backlight, no matter its components or its configuration, still incrementally and negatively affects display depth and power consumption. Elimination of the backlight is a key selling point of the OLED, a long-touted supposed successor to LCDs that's finally beginning to deliver on its promise, at least in small-format applications. OLEDs' inherent emissive electroluminescence requires no supplemental backlight. Unlike backlight-inclusive displays, they are flexible, opening the doors to new applications, such as electronics-augmented clothing and roll-up signage. Their wide viewing angles, vivid colors, and perceived contrast ratio in dim viewing settings are impressive. They also deliver several orders of magnitude faster response than do LCDs.

But OLEDs' limited operating lifetime, particularly for blue-spectrum organic materials, has to date left them feasible only with highly disposable electronics devices. Before hard failure,

all OLED subpixels exhibit degradation over time, creating undesirable color-balance shifts. OLEDs, being non-reflective in nature, tend to be difficult to discern in high-ambient-lighting settings, such as with direct-sunlight illumination. Unlike LCDs, and like CRTs and plasma displays, they are prone to permanent persistence, or burn-in, in response to the lengthy display of a stationary image (see **sidebar** "Plasma lives to fight another day; SED fades away"). They deliver excellent power consumption with mostly dark content. However, their battery drain when displaying mostly light material, such as the common arrangement of dark text on a light or white background, can be significantly higher than that of an LCD/backlight combination.

High-volume, cost-effective OLED manufacturing remains a challenge, and there are a limited number of suppliers. For example, although HTC over the past year launched a series of OLED-based mobile phones, the company has subsequently retrofitted them with LCDs in response to supply short-

V-Infinity

POWER FROM THE WALL TO THE IC

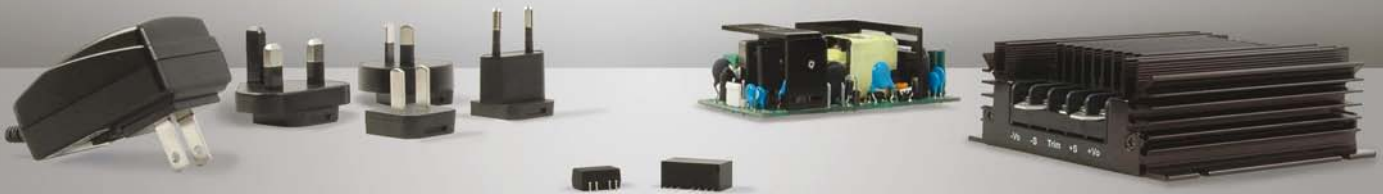

dc-dc converters

- digital point-of-load
- isolated board mount
- isolated chassis mount
- non-isolated regulators
- LED driver modules

ac-dc power supplies

- embedded power
- open frame
- chassis mount
- DIN rail
- external adapters
- wall plug
- desk-top
- multi-blade

Connect with us:



call: 800-275-4899

visit: www.cui.com/v-infinity



falls, leaving currently dominant OLED supplier Samsung to use the small-format displays in its own branded cameras, cell phones, and other products. And Samsung's frequently stated ambition to obsolete LCD TVs with large-format OLED successors, although an understandable response to the looming threat of emerging LCD competition from companies in Taiwan, China, and elsewhere, seems to be little more than a pipe dream, at least for the near term (Reference 11).

As for the front of the display, an increasing percentage of LCDs employ glossy screens instead of matte, anti-glare counterparts. In response, specialty suppliers have sprung up to, for a warranty-busting and often-substantial fee, retrofit glossy-only computers with matte aftermarket displays. Applying a matte film to the front of a glossy LCD produces a comparable and more cost-effective effect. The heated debates between advocates in both camps are reminiscent of the arguments about matte and glossy photographs, which have comparable sets of pros and cons. Matte screens don't exhibit egregious reflections and consequently may be easier on the eyes for extended viewing periods and outdoors—that is, if the backlight is strong enough. Detractors point out their decreased brightness and contrast, which promoters alternatively describe as more accurate. Conversely, glossy screens' vibrant—albeit, according to image professionals, inaccurate—colors make them the often-preferred option for playing games or watching movies, thereby explaining their burgeoning popularity. However, high-ambient-lighting conditions result in glare and reflections from the display's surroundings. In both cases, the incremental attenuation and other alteration effects of a potentially present touchscreen also beg for your attention.

E-BOOK ASCENDANTS

Whether LCD or OLED, displays' ever-faster responses have enabled them to finally usurp CRTs in performance-demanding usage environments, such as computer and multiplayer-gaming setups. They've also, in combination with evolving backlight improvements, led to a numbers race among suppliers continually striving to one-up or, depending on the specification, “one-down” each

other, albeit with often-dubious real-life relevance. Overdriving a pixel to encourage it to more quickly switch states is, for example, a meaningful technique only when moving it from fully open to fully closed or vice versa. Subtler transitions take much longer than their more abrupt counterparts.

Similarly, not too long ago, people considered a 60-Hz display-refresh rate as state of the art, whereas 120-Hz panels are now commonplace, and 240-Hz and higher refresh-rate displays are entering the mainstream. Again, some practical benefit exists to such techniques. These benefits include enabling the display-refresh rate to more evenly match up with the 24-Hz cadence of film-captured material, for example; eliminating “judder” in fast-action sequences, such as sports content; and bringing 3-D playback to the living

THE MICROCAPSULES RETAIN THEIR ORIENTATIONS EVEN AFTER REMOVAL OF THE ELECTRIC FIELD—UNTIL FIELD REAPPLICATION AND REVERSAL.

room (Reference 12). Yet, a bungling implementation may ironically produce results that are worse than those of a slower-refresh predecessor. Intermediary frame creation can take the form of either previous-frame repetition or interpolation between successive source frames. Thanks to LED backlights' rapid illumination and extinction attributes, intermediary black frames—those with the backlight turned off—often also find use.

Peer at the printed page of a monochrome book or newspaper, and you'll likely realize that a full-color LCD or OLED represents overkill for an electronic-paper successor. This discrepancy explains the impressive industry embrace of E Ink's bimodal display medium, which the company based on technology developed at the Massachusetts Institute of Technology's Media Lab and today finds use in most e-book read-

ers and similar devices. As the company literature (Reference 13) explains, “The principal components of electronic ink are millions of tiny microcapsules, about the diameter of a human hair. In one incarnation, each microcapsule contains positively charged white particles and negatively charged black particles suspended in a clear fluid. When a negative electric field is applied, the white particles move to the top of the microcapsule to become visible to the reader. This [approach] makes the surface appear white at that location. At the same time, an opposite electric field pulls the black particles to the bottom of the microcapsules where they are hidden. By reversing this process, the black particles appear at the top of the capsule, which now makes the surface appear dark at that location.”

E Ink's microcapsules retain their orientations even after removal of the electric field—until subsequent field reapplication and reversal. As a result, E Ink-based devices deliver much longer battery life than LCD or OLED alternatives. The displays are easy to read even in bright-sunlight settings, have nearly 180° viewing angles, and deliver 150- to 200-dpi resolution. E Ink this year unveiled its second-generation Pearl technology, with a claimed 50% improvement in contrast ratio. However, although the manufacturer claims that Pearl has a less-than-1-msec response rate, refresh rates are on the order of only a few frames or less per second, leading to slow page-turning, annoying “ghosting” artifacts, and a practical inability to display even low-frame-rate video content.

Color variants of E Ink displays are not yet in production, and the prototypes at last summer's SID conference and other recent industry forums have been underwhelming, with limited palettes and low contrast ratios—both in an absolute sense and compared with LCD and OLED counterparts. These shortcomings are problematic for color newspapers, such as *USA Today*, the Sunday comics, and electronic magazine subscriptions. They also render E Ink displays incompatible with “enlightened” electronic-literature versions, which embrace the new medium's capabilities by including animation sequences, video clips, and the like. For these and other reasons, Barnes &

Noble selected a 1024×600-pixel, 7-in. LCD for its \$249 Nook color e-reader, which the company introduced in October. The company is treading a tenuous and unclear pricing path between less expensive monochrome e-books and fully featured color-tablet computers (Figure 4).

Several upstart display developers strive to combine the best attributes of LCD, OLED, and E Ink, and they hope that market success will follow. One of the more well-known aspirants is Pixel Qi, whose founder, Mary Lou Jepsen, was formerly the chief technology officer of the OLPC (One Laptop per Child) project at MIT's Media Lab. The company's displays are largely compatible with LCD-manufacturing equipment and production flows, a key factor in the hoped-for rapid supply ramp-up and equally rapid cost decreases. Pixel Qi devices can optionally switch off their backlights, transforming from full-color conventional displays into reflective monochrome screens that, like E Ink counterparts, are easy to read in direct sunlight. The OLPC XO-1 first employed the Pixel Qi display, and Notion Ink's upcoming Adam tablet, which the company based on Nvidia's Tegra

2 ARM CPU, also uses Pixel Qi. Pixel Qi also sells the \$275 3Qi display to do-it-yourself hackers who want to replace the 10-in. LCDs in their netbooks.

Qualcomm's Mirasol display represents a curious move for a company best known for its plethora of wireless-communication patents and the semiconductor devices that employ them. Mirasol, a MEMS (microelectromechanical-system)-based technology, uses IMOD (interferometric modulation), which functions similar to the way in which a butterfly wing refracts light into a rainbow of colors. Each display element comprises two conductive plates, forming an optically resonant cavity. One plate is a thin-film stack on a glass substrate, and the other is a reflective membrane suspended overhead; an air gap separates them. The IMOD element has two stable states. With no applied voltage, the plates remain separate. Applying a voltage differential draws the plates together by electrostatic attraction.

When ambient light hits the element, with no applied voltage to the plates, the light reflects off both the top of the thin-film stack and the reflective membrane above it. Depending on the optical cavity's height, the light of certain wavelengths reflecting off the membrane is slightly out of phase with the light reflecting off the thin-film structure. Some wavelengths constructively interfere, whereas others destructively interfere. The human eye and brain perceive as color the resultant amplification of some wavelengths and not others. Collapsing the plates' gap by applying voltage results in constructive interference only at ultraviolet wavelengths, invisible to the human eye, translating to a perceived-black absence of color. Sequentially ordered red, green, and blue constructive-wavelength subpixel elements, as with LCDs and OLEDs, construct pixels that output all color combinations, including white.

To date, Qualcomm's few Mirasol design wins have been in small-format monochrome displays from a modest Taiwanese facility in partnership with Foxlink. However, Qualcomm has recently begun showing limited-gamut-color and somewhat-dim prototypes and is reportedly building a \$2 billion dedicated manufacturing facility after securing a major design win (Reference 14). **EDN**

REFERENCES

- 1 Dipert, Brian, "A magic touch: The concept's sound, but implementation options abound," *EDN*, Nov 4, 2010, pg 26, <http://bit.ly/dxyLuQ>.
- 2 Crow, James Mitchell, "Ten Years To Save the Touchscreen," *New Scientist*, Oct 20, 2010, <http://gizmo.do/dajhqi>.
- 3 Dipert, Brian, "Display technology's results are compelling, but legacy is un'clear'," *EDN*, Oct 26, 2000, pg 63, <http://bit.ly/aKjiXV>.
- 4 Carnoy, David, "Sharp intros industry first four-color pixels," *CNET*, Jan 6, 2010, <http://bit.ly/dcnppC>.
- 5 Foresman, Chris, "Apple CMY display design could be boon for print production," *Ars Technica*, <http://bit.ly/8Zh04b>.
- 6 Dipert, Brian, "Blu-ray: Dogged by delays, will it still have its day?" *EDN*, July 29, 2010, pg 28, <http://bit.ly/aLxLGM>.
- 7 Dipert, Brian, "Connecting systems to displays with DVI, HDMI, and DisplayPort: What we got here is failure to communicate," *EDN*, Jan 4, 2007, pg 46, <http://bit.ly/c5YtAE>.
- 8 "HDTV Has Ruined the LCD Market," *Slashdot*, <http://bit.ly/90Y3y2>.
- 9 "Why Are We Losing Vertical Pixels?" *Slashdot*, <http://bit.ly/blOM1x>.
- 10 Taub, Eric A, "UK Nixes Samsung's 'LED' TV Campaign," *The New York Times*, Sept 8, 2009, <http://nyti.ms/aBs5WS>.
- 11 Dipert, Brian, "The large-screen OLED TV: Samsung may indeed make it a reality, and Taiwan and China may be key," *EDN*, June 17, 2010, <http://bit.ly/bRLhx5>.
- 12 Dipert, Brian, "Coming soon: 3-D TV," *EDN*, April 8, 2010, pg 23, <http://bit.ly/dbBANv>.
- 13 Electronic ink, Electronic Paper Displays, <http://bit.ly/arlv1d>.
- 14 Savov, Vlad, "Qualcomm building a \$2b Mirasol plant after winning 'major client'?" *Engadget*, Aug 20, 2010, <http://engt.co/96Vx2L>.

FOR MORE INFORMATION

Amazon www.amazon.com	NHK www.nhk.or.jp
Apple www.apple.com	Notion Ink www.notionink.com
ARM www.arm.com	Nouvoyance www.nouvoyance.com
Barnes & Noble www.barnesandnoble.com	Nvidia www.nvidia.com
Canon www.canon.com	Ortustech www.ortustech.co.jp
Casio www.casio.com	Panasonic www.panasonic.com
Eastman Kodak www.kodak.com	Pixel Qi www.pixelqi.com
Foxlink www.foxlink.com	Qualcomm www.qualcomm.com
Hitachi www.hitachi.com	Samsung www.samsung.com
HTC www.htc.com	Sharp www.sharppusa.com
LG Display www.lg.com	Toppan www.toppan.co.jp
Microsoft www.microsoft.com	Toshiba www.toshiba.com
MIT Media Lab www.media.mit.edu	
Nano-Proprietary/ Applied Nanotech www.appliednanotech.net	



ADDING MODELS OF THERMAL AND OPTICAL BEHAVIOR PROVIDES MORE COMPLETE VERIFICATION OF PERFORMANCE AND RELIABILITY.

Simulation of electronic circuits and systems has long focused on the analysis of electrical signals: voltage or current waveforms for analog engineers and binary bit patterns for digital engineers. Now that IC density has grown into the billions of transistors, however, on-chip management of power dissipation has become more critical. You must also consider the physics of how that power converts into performance-degrading heat. Verification of system performance and reliability requires analysis of both thermal and electrical conduction, involving modeling of materials that you previously may have ignored, and the physical interaction from a chip to its package and surrounding environment.

MULTIPHYSICS SIMULATION ENHANCES ELECTRONICS SYSTEM DESIGN

BY MIKE DEMLER • TECHNICAL EDITOR

Meanwhile, many of the highest-growth applications for electronics involve control of illumination. New technology for flat-panel displays, LED lighting, solar energy, and high-speed interconnect requires analysis of the physics involved in electro-optical behavior.

DIVIDE AND CONQUER

Multiphysics simulation is a tool for analyzing systems with disparate physical behaviors that disparate mathematical models describe. The physical behaviors may be intentional components of a design, such as in electromechanical or electro-optical systems, or they may be an unavoidable aspect of the physical realization, as is the case for most electrothermal behavior. Approaches to simulation also vary—from co-simulation of tightly coupled systems



Mouser is proud to give an approving nod to those who never stop thinking what's next. To all those inquisitive minds that challenge convention by asking the simple question... What if? The ones committed to developing new technological breakthroughs that make all our lives easier. We want you to know that we're here to support you and all your ideas. No matter how far out there they might seem.

Keep dreaming.



mouser.com The Newest Products For Your Newest Designs™



a tti company

SOFTWARE MODELS DRIVE NEXT-GENERATION CARS

Martin Rowe and Jennae Cohen, Test & Measurement World

Software lets engineers model and simulate everything from silicon to sheet metal. The EcoCar team at RHIT (Rose-Hulman Institute of Technology) is learning how to model an entire vehicle with The MathWorks' Matlab and Simulink as part of the EcoCar competition.

In the three-year competition, now in its final year, students from 16 colleges compete to design an environmentally friendly car (Reference A). Students spent the first year developing a software model that lets them evaluate the impact of their proposed modifications to a General Motors vehicle.

The system model comprises mathematical models of the vehicle's components that the students purchase, modify, or adapt to improve fuel efficiency. To get the students started on the model, GM supplied data on the vehicle's parts and systems. "We took an approach of a system integrator, and we selected components that would get the job done," says Professor Zac Chambers, one of the RHIT project advisors.

From Matlab models that connect through Simulink, team members roughly calculated the size and power characteristics of the components for their hybrid vehicle. Students and faculty ran cases in which they compared architectures to see how they performed for the competition metrics. For example, they examined the amount of power an engine required to meet the vehicle's unassisted

towing requirement should the battery fail.

Figure A shows the software hierarchy of the vehicle model. This simplified diagram follows the path from the overall vehicle model to the models that simulate the engine. Students wrote the simulation code with Matlab and used Simulink to tie the models together into a system. From the Simulink model, team members narrowed down the choices of engines that GM had available for them.

They first tried a 1.3-liter diesel engine, the smallest, in their model.

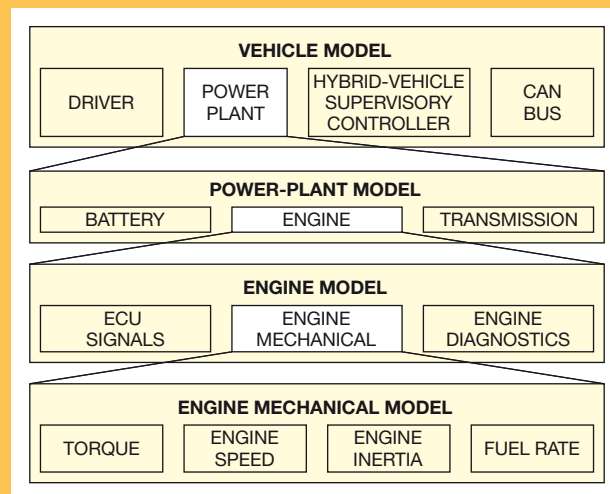

Figure A The path proceeds from the overall vehicle model to the models that simulate the engine.

"In choosing the 1.3-liter turbo diesel, we used Siemens NX CAD [computer-aided-design] software to make sure the parts we designed would fit inside the vehicle," says Chambers. "From the Simulink model, we can figure out the rough power requirements for the engine and then, from that figure, narrow down the choices of engines that

GM had available for us. We then used the NX software to determine whether it would mechanically fit into the vehicle when connected to the vehicle's automatic transmission."

The Matlab/Simulink system model runs in a National Instruments PXI instrument chassis. Analog, digital, and communications I/O cards in the chassis connect to external controls that simulate control signals, such as the gas and the brake. Instruments also collect data from the ECU (engine-control unit) from sensors in the vehicle.

Students use the model to predict how the actual car will run. Software components of the model started as simple equations. Along with the plant model, they have a model of the overall vehicle supervisor and the competition metrics they must log and a model of how the driver will drive the vehicle based on a driving cycle. They have also incorpo-

rated CAN (controller-area-network) interfacing so components can model working on the vehicle network.

"We started with the high-level plant model and made incredibly simple mathematical models," says Chambers. "For example, our first model of the vehicle's engine [an electric motor] was a constant torque source that put out the maximum torque and had no rpm limits. With a simple motor like that, you can start hooking that motor up to the vehicle. From these simple models, you can get a feel for how the vehicle should respond. Then, you can develop a control strategy and verify that the response is what you expect."

With its measurement and signal-generation cards, the PXI system let students collect 45 minutes of data, compare test data with the model, and refine the model. "We have a graduate student who is developing sophisticated optimization tools," Chambers says. "Graduate students will use the model to teach undergraduate students about modeling-system design."

REFERENCE

▲ Nelson, Rick, "Model-based design and early verification aid designers," *EDN*, Dec 15, 2009, pg 22, <http://bit.ly/boVtmT>.

Martin Rowe is senior technical editor and Jennae Cohen is a contributing editor at *EDN's* sister publication *Test & Measurement World*.

AT A GLANCE

- Increasing system-design complexity drives the need to analyze nonelectrical behavior.
- Multiphysics simulation adds electrothermal and electro-optical models to complete system verification.
- On-chip analysis of temperature variations detects performance and reliability problems.
- A divide-and-conquer approach combines models that experts in different domains develop.

to a divide-and-conquer approach that uses specialized tools and languages for each domain and APIs (application-programming interfaces) to pass data between the various models.

With everything from toothbrushes to our cars now using embedded electronics, multiphysics is a hot topic. Multidomain simulators, on the other hand, have been around for a long time. The earliest commercial multidomain tool is Analog's Mast language, which debuted in 1986 and still finds use in Synopsys' Saber simulator.

Lee Johnson, business-development manager at Synopsys' Saber unit, sees an increasing emphasis on total system design with a focus on the components that surround the chip. Multiphysics simulation is gaining most of its traction, Johnson says, because of the many bidirectional interdependencies and interactions that occur in such systems. With electronic actuation replacing hydraulics in many vehicles,

multiphysics simulation is necessary for modeling the interaction between controllers and their loads.

The trend toward the development of "green" energy is also creating new applications for multiphysics simulation, requiring sophisticated models to incorporate solar arrays and new battery technologies. The ability to integrate high-voltage components, combining electrical and electromagnetic behavior with electrothermal characteristics, thus becomes a necessity in high-power systems.

Darrell Teegarden, business-unit director at Mentor Graphics, says that system complexity is making it more difficult for his customers to design products. A complete system design commonly involves embedded software, an RTOS, sensors, actuators, a DSP, and energy sources. Teegarden, co-author of *The System Designer's Guide to VHDL-AMS* (Reference 1), sees accelerating interest in system-modeling languages because of the need to describe behavior across multiple disciplines.

Modeling remains the biggest challenge, however, relying on experts in each domain to choose the language that best fits their piece of the overall system. The divide-and-conquer approach may involve executable UML (unified modeling language) to generate C code, Spice for analog components, or data-driven models from engineering tests of prototypes. The Mentor SVX (SystemVision X) client environment eases the job by providing an interface to National Instruments LabView software for test-program development and execution throughout the design cycle.

The SVX virtual-execution environment dynamically connects domain-specific modeling and software tools over a secure, managed signal channel. A C/C++ API makes it easy for embedded application software to interact with models of control systems, multiphysics subsystems, sensors and actuators, and analog and digital electronics.

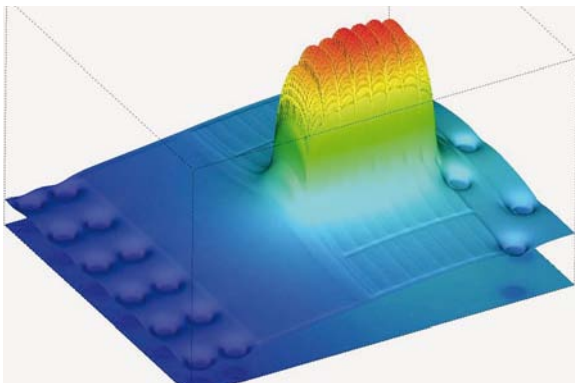

Figure 1 A thermal profile for an RF-antenna switch demonstrates the range of temperature variation within a cell-phone IC (courtesy Gradient).

Searching for Power?

Harsh environment

PFE Series



- ◆ 300 to 1500W
- ◆ 12 - 48V output
- ◆ -40 to +100°C ambient

Medical

SWS, NV, Vega & EFE series



- ◆ 15 to 1000W
- ◆ Single or multiple output
- ◆ 4kVAC isolation

Industrial

HWS



- ◆ 15 to 1800W
- ◆ 3.3 - 60V output
- ◆ Limited Lifetime Warranty

For more information on how TDK-Lambda can help you power your unique applications, visit our web site at www.us.tdk-lambda.com/lp/ or call 1-800-LAMBDA-4

TDK-Lambda
Innovating Reliable Power

PICO

AC-DC Converters
Power Factor Corrected
5-300Vdc
Isolated DC Output
Low Cost
Industrial

**UP TO
300
WATTS**

Two Units in One
AC1 Series



Universal AC Input
47-400Hz
Input Frequency

- **STANDARD: 5 to 300 vdc regulated, ISOLATED outputs/Fixed frequency**
- **ALL in ONE compact full brick module, 2.5" x 4.6" x 0.8" Vacuum encapsulated for use in rugged environments**
- **Lower cost for your Industrial applications**
- **Maximize your design up to 300 watt models**
- **Meets Harmonic Distortion specifications**
- **.99 Power factor rating at operational levels**
- **Expanded operating temperatures available -40 & -55C, +85 & 100C base plate**
- **Custom models available**

www.picoelectronics.com

Send Direct
for free PICO Catalog
E-Mail: info@picoelectronics.com

PICO Electronics, Inc.

143 Sparks Ave, Pelham, NY 10803-1837

Call Toll Free 800-431-1064 • FAX 914-738-8225

TEMPERATURE VARIATION

Engineers have routinely limited the analysis of the impact of temperature variation on an IC design to corner analysis, which entails varying the simulated temperature for the whole chip or function block from nominal to the hot/cold extremes of a device's operating range. Corner simulation operates on the assumption that the chip substrate is an isothermal surface and that there is no variation in either the lateral or the vertical directions through the various insulating and conductive materials. With the higher levels of integration in today's SOCs (systems on chips), especially the increasing number of RF and analog- and mixed-signal functions, that assumption no longer holds.

Adi Srinivasan, vice president of engineering for EDA start-up Gradient, points out that on-chip temperature variations can often be 25°C or greater. These temperature effects disturb device-matching assumptions in sensitive analog circuits, introducing another variable for designers who struggle to account for on-chip statistical variations in nanometer-device characteristics. Failure to properly account for these temperature excursions can also lead to device failure. Accurate simulation of IC-temperature variations requires cou-

pling the physics of thermal conduction to the models of dynamic electrical conduction, adding 3-D models of the materials that compose the insulating layers around active devices, and conductive paths to the device package.

Gradient's HeatWave 3-D electro-thermal simulator for chips and stacked-die SIPs (systems in packages) computes the temperature profile inside a die, allowing annotation of the data into a standard circuit simulator to make results more accurate (Figure 1). For most SOCs that rely on dynamic on-chip power management, HeatWave can compute a transient-temperature map, showing variations over time as a function of circuit operation. HeatWave integrates with industry-standard custom and analog IC design flows, taking as its inputs the chip's layout geometry, power sources from the circuit netlist, package specifications, and a file that describes the materials in the semiconductor-manufacturing process. The interactive GUI (graphical-user-interface) mode lets users navigate a chip both horizontally and vertically to examine the temperatures and heat-conduction paths throughout various device layers.

Gradient also offers HeatWave 3DIC for steady-state analysis of heterogeneous stacked-die packages (Reference 2), which are increasingly extending Moore's Law into the vertical dimension. The thinning of chips, necessary for such packaging, and the addition of interdie insulators and

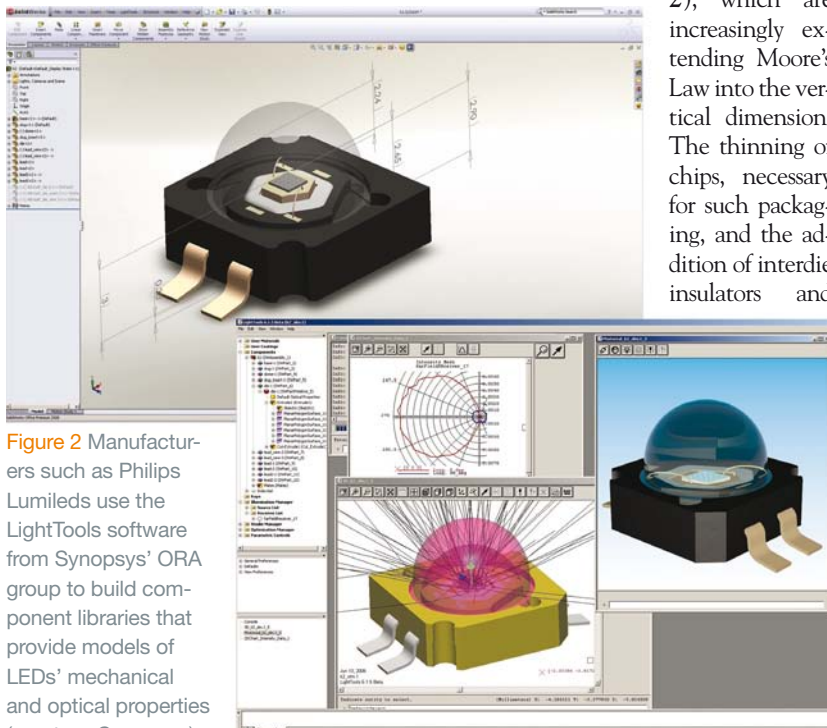

Figure 2 Manufacturers such as Philips Lumileds use the LightTools software from Synopsys' ORA group to build component libraries that provide models of LEDs' mechanical and optical properties (courtesy Synopsys).

FOR MORE INFORMATION

Ansys
www.ansys.com

Gradient
www.gradient-da.com

The MathWorks
www.mathworks.com

Mentor Graphics
www.mentor.com

National Instruments
www.ni.com

National Semiconductor
www.national.com

Optical Research Associates
www.opticalres.com

Philips Lumileds
www.philipslumileds.com

Synopsys
www.synopsys.com

molding compounds, which can negatively affect heat-conduction paths, further complicate the electrothermal physics of stacked-die configurations.

A COMPLETE APPROACH

For complete system optimization, the analysis of electrothermal effects that begin on-chip at the nanometer scale continues outward to the millimeter scale of the package and the PCB (printed-circuit board). At this stage, overdesign of heat sinks and cooling systems can add unnecessary cost, whereas inaccurate modeling of the physics of heating in copper traces can result in reliability problems. Electromechanical effects also enter the picture as a result of the thermal stress of electronic components and the interfaces between dissimilar materials in the chip/package/board stack.

Ansys' Icepak optimizes the design of cooling systems by analyzing heat transfer and fluid flow in IC packages, PCBs, and complete electronic systems. Steve Scampoli, lead product manager for Ansys' multiphysics, describes Icepak as a unique approach that can analyze electronic cooling at multiple levels—from chip packages to PCBs to systems for data centers. Icepak imports electronic and mechanical CAD (computer-aided-design) data from EDA software, such as Cadence's Allegro PCB-design tool and APD (Advanced Package Designer). A connection to the Ansys SIwave (signal-integrity-wave) and power-integrity-analysis tool enables developers to import dc-power-distribution profiles for thermal analysis of heating in the conductors of PCBs and packages.

CRTs have gone the way of the dinosaurs, and energy-efficient options, such as LEDs, are replacing incandescent bulbs, so electronics systems for lighting control are growing in importance. The recent "Designing with LEDs Workshop," which EDN sponsored, devot-

ed a day to topics such as power and thermal management, optics and light measurement, and LEDs and solar power. Along with electrothermal behavior, the electro-optical interfaces in lighting systems require a multiphysics approach for system optimization.

To examine trade-offs in lighting-system design, National Semiconductor is providing its LED-simulation tool free online (Reference 3). The Webench LED Architect allows users to select models for LEDs, passive components, and heat sinks from a variety of manufacturers, aiding in the selection of the appropriate National Semiconductor PowerWise LED driver.

EDA vendors have also moved deeper into optical design. For example, Synopsys recently acquired the 47-year-old ORA (Optical Research Associates), whose LightTools 3-D design tool provides virtual prototyping, simulation, and illumination applications for optical design (Figure 2). According to Tom Walker, R&D director in the Optical Solutions Group at Synopsys, LightTools addresses the physics of phosphors and applications in which designers must "coerce photons." LightTools finds use in LED design, backlighting for LCDs in cell phones, and modeling and analysis of solar-collection systems. Synopsys has added ORA's products to the TCAD (technology-computer-aided-design) product portfolio, which also includes the Sentauros device simulator. Sentauros simulates the electrical, thermal, and optical characteristics of semiconductor devices. EDN

REFERENCES

- 1 Ashenden, Peter J; Gregory J Peterson; and Darrell A Teegarden, *The System Designer's Guide to VHDL-AMS*, Elsevier, 2003, ISBN: 1-55860-749-8.
- 2 Nelson, Rick, "The time is now for 3-D stacked die" *EDN*, July 15, 2010, pg 9, <http://bit.ly/aWasZ5>.
- 3 Conner, Margery, "LED-simulation tool balances cost, heat, and space," *EDN*, Oct 7, 2010, <http://bit.ly/bAe5CL>.



PICO

SURFACEMOUNT (and thru-hole) Transformers & Inductors

Size does matter!

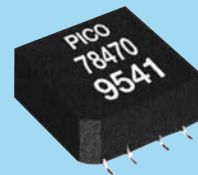

from
low-
profile

.19"ht.

- **Audio Transformers**
- **Pulse Transformers**
- **DC-DC Converter Transformers**
- **MultiPlex Data Bus Transformers**
- **Power & EMI Inductors**

See Pico's full Catalog immediately
www.picoelectronics.com

or send direct for free PICO Catalog
Call Toll Free 800 431-1064
Fax 914-738-8225

E Mail: info@picoelectronics.com

PICO Electronics, Inc.

143 Sparks Ave. Pelham, N.Y. 10803-1837



Delivery - Stock to one week

EDN HOT 100 PRODUCTS

It may not be as much fun as holiday shopping, but selecting the most innovative and significant product and technology offerings of 2010 is a task our editors enjoy. *EDN* proudly presents its list of the Hot 100 products that in 2010 heated up the electronics world and

grabbed the attention of our editors and our readers.

Visit www.edn.com/2010hot100 for links to *EDN*'s original coverage of each of the products you see listed on these pages. For continuous new-product coverage, go to www.edn.com/productfeed.

ANALOG

Analog Devices

AD5791 20-bit DAC
www.analog.com

Fairchild Semiconductor

FAN739x, high- and low-side gate driver
www.fairchildsemi.com

Intersil

ISL59605 MegaQ video equalizer
www.intersil.com

Linear Technology Corp

LT6656 low-power voltage reference
www.linear.com

Maxim Integrated Products

MAX11210 single-channel, 24-bit ADC
www.maxim-ic.com

Microchip Technology

MCP4361 quad potentiometer and MCP4362 quad rheostat
www.microchip.com

National Semiconductor

ADC12D1800 ADC
www.national.com

National Semiconductor

DS92LX2121/2 SERDES
www.national.com

Nuvoton

ISD61S00 audio-chip recorder
www.nuvoton-usa.com

Silicon Labs

Si270x class-D audio amplifier
www.silabs.com

Texas Instruments

OPA1641, dual OPA1642, and quad OPA1644 operational amplifiers
www.ti.com

Wolfson

Microelectronics
WM8912 audio DAC
www.wolfsonmicro.com

COMMUNICATIONS AND NETWORKING

Atheros Communications

AR7400 power-line-networking chip set
www.atheros.com

Quantenna

QHS600 4x4 MIMO 802.11n chip set
www.quantenna.com

Sigma Designs

CG511x power-line-networking chip set
www.sigmadesigns.com

Summit Semiconductor

FS848 wireless audio transceiver
www.summitsemi.com

COMPONENTS

Cree

XLamp MPL EasyWhite LED
www.cree.com

Digi International

iDigi machine-to-machine network management
www.idigi.com

Diodes Inc

ZXTN2602DMF 20V bipolar transistors
www.diodes.com

Efficient Power Conversion Corp

GaN power transistors
www.epc-co.com

Infineon

OptiMOS MOSFETs
www.infineon.com

International Rectifier

iP2010 and iP2011 GaN power transistors
www.irf.com

Luminus Devices

UV CBT-120 UV LED
www.luminus.com

Molex

Helieon LED module
www.molex.com

National Semiconductor

Webench LED Architect
www.national.com

Philips Lumileds

Luxeon Rebel LEDs for indoor illumination
www.philipslumileds.com

Texas Instruments

CSD86350Q5D Power Block synchronous MOSFET half-bridge device
www.ti.com

Vishay

SiR880DP FET
www.vishay.com

DEVELOPMENT KITS

Avnet Electronics Marketing

Xilinx Spartan-6 FPGA/DSP-development kit
www.avnet.com

Texas Instruments

LaunchPad development board
www.ti.com

EDA

Atrenta

SpyGlass-Physical RTL design-closure-estimation tool
www.atrenta.com

Magma Design Automation

Tekton STA/extraction/Spice environment
www.magma-da.com



Mentor Graphics
Calibre InRoute Olympus routing kernel
www.mentor.com

Mentor Graphics
SystemC support for Catapult C
www.mentor.com

Synopsys
DesignWare STAR (self-test-and-repair) ECC IP
www.synopsys.com

LOGIC ANALYZERS

LeCroy
LogicStudio 16 logic analyzer
www.lecroy.com

Tektronix
TLA6000 midrange logic analyzers
www.tektronix.com

MEMORY AND STORAGE

IM Flash Technologies
25-nm, 3-bit-per-cell MLC NAND-flash memory
www.imftech.com

Micron Technology
C300 and P300 solid-state drives
www.micron.com

PLX Technology
NAS 7820, 7821, and 7825 storage controllers
www.plxtech.com

SandForce
SF-2000 solid-state-drive-controller series
www.sandforce.com

Seagate Technology
Momentus XT hybrid hard-disk drive
www.seagate.com

Western Digital
Four-platter, 3-Tbyte hard-disk drives
www.westerndigital.com

MICROCONTROLLERS AND PROCESSORS

AMD
Bobcat Fusion CPU-plus-APU
www.amd.com

ARM
Cortex-A15 CPU core
www.arm.com

Freescale Semiconductor
Kinetis ARM-based microcontrollers
www.freescale.com

Intel
Lincroft Atom CPU and Moorestown chip set
www.intel.com

Texas Instruments
TMS320C66x fixed- and floating-point cores
www.ti.com

Texas Instruments
Integra ARM-based micro-controller-plus-DSP family
www.ti.com

Vitesse
VSC7460 Jaguar carrier-Ethernet switch
www.vitesse.com

MULTIMEDIA ICs

AMD
Radeon HD 6800 series graphics processors
www.amd.com

Zenverge
ZN100, ZN150, and ZN200 audio, video, and DRM transcoders
www.zenverge.com

OSCILLOSCOPES

Agilent Technologies
86100D DCA-X (extended) wide-bandwidth equivalent-time-sampling oscilloscope
www.agilent.com

Rohde & Schwarz
RTO 2-GHz oscilloscopes
www.rohde-schwarz.com

POWER

Enpirion
EN6300 family of voltage mode synchronous buck dc/dc converters
www.enpirion.com

Fairchild Semiconductor
FAN5365 digitally programmable regulator
www.fairchildsemi.com

Freescale Semiconductor
MCF51EM256 smart-meter IC
www.freescale.com

Linear Technology Corp
LT4180 virtual remote sense-controller IC
www.linear.com

Linear Technology Corp
LTC3108 energy-harvesting boost regulator
www.linear.com

National Semiconductor
LMZ series of Simple Switcher modules
www.national.com

National Semiconductor
LM5035C PWM controller
www.national.com

Picor
Cool-Power platform
www.picorpower.com

Powercast
TX91501 transmitter module
www.powercastco.com

Semtech
SC174 and SC173 buck regulators
www.semtech.com

Silicon Labs
Si8420 isolator
www.silabs.com

Skinny Bytes
Touchscreen AIO
www.skinnybytes.com

STMicroelectronics
SPV1001 bypass diode
www.st.com

Teridian
78M6618 power-metering chip
www.teridian.com

Texas Instruments
TPS7A30 negative-output low-dropout linear regulator
www.ti.com

RF

Hittite Microwave
HMC-C070 synthesizer
www.hittite.com

Marvell
88DE8500 hybrid silicon tuner
www.marvell.com

Maxim Integrated Products
MAX2042 upconverting and downconverting, double-balanced passive mixer
www.maxim-ic.com

Peregrine Semiconductor
PE42662 SP6T (single-pole/six-throw) RF switch
www.peregrine-semi.com

Peregrine Semiconductor
PE42440 SP4T (single-pole/four-throw) RF switch
www.peregrine-semi.com

Radiometrix
TXL2/RXL2 9600-baud RF modem
www.radiometrix.com

RFMD
RF3931 GaN unmatched power transistors
www.rfmd.com

Scintera Networks
SC1887 adaptive RF predistortion chip
www.scinteranetworks.com

Texas Instruments
CC1190 RF sub-GHz range extender
www.ti.com

Texas Instruments
CC2590/1 RF 2.4-GHz range extender
www.ti.com

SEMICONDUCTOR PROCESSES AND IP

IBM
CMOS-7HV high-voltage, mixed-signal process
www.ibm.com

SIGNAL ANALYZERS

Anritsu
MS2830A 9-kHz to 3.6-, 6-, or 13.5-GHz signal analyzers
www.us.anritsu.com

SIGNAL GENERATORS

Agilent Technologies
81180A 4.2G-sample/sec arbitrary-waveform generator
www.agilent.com

Anritsu
MG3690C 70-GHz RF/microwave-signal generator
www.us.anritsu.com

LeCroy
ArbStudio arbitrary-waveform generator
www.lecroy.com

SINGLE-BOARD COMPUTERS

Adlink
Ampro ReadyBoard 740 Atom-based single-board computer
www.adlink.com

SINGLE-BOARD COMPUTERS (Continued)

WinSystems

PCM-VDX-2-512 Vortex86DX-processor-based PC/104 1-GHz single-board computer
www.winsystems.com

SOFTWARE/EDA FOR BOARD/SYSTEM DESIGN

Cadence Design Systems

Allegro PCB SI signal-integrity tool
www.cadence.com

CST

Studio Suite 2010 for EM, mechanical, and thermal simulation

www.cst.com

The MathWorks

Target Support Package for TI C2000 Piccolo microcontrollers
www.mathworks.com

Mentor Graphics

FloTherm 9 computational fluid-dynamics software
www.mentor.com

National Instruments

LabView 2010 graphical-design software
www.ni.com

National Semiconductor

Webench FPGA Power Architect
www.national.com

Power Integrations

PI Expert
power-integrity-analysis tool
www.powerint.com

Sigrity

Channel Designer
power-integrity-analysis tool
www.sigrity.com

Sunstone Circuits

PCB123 Version 4 circuit-design software
www.sunstone.com

SOURCE-MEASURE UNITS

Agilent Technologies

N6781A source-measure unit for battery-drain analysis
www.agilent.com

SPECTRUM ANALYZERS

Agilent Technologies

N9342C HSA 100-kHz to 7-GHz handheld spectrum analyzer
www.agilent.com

Anritsu

MS272xC Spectrum Master handheld RF spectrum analyzers
www.us.anritsu.com

WIRELESS TEST

Aeroflex

7100 Series fading simulator with support for LTE bandwidths to 20 MHz with a frequency range to 6 GHz
www.aeroflex.com

National Instruments

Version 2.0 WLAN software suite for IEEE 802.11n testing
www.ni.com



Accelerate Your Projects into the Future

AEROCON

AEROSPACE • AVIATION • DEFENSE



FEBRUARY 8-10, 2011

Anaheim Convention Center
Anaheim, California

MARCH 16-17, 2011

Orange County Convention Center
Orlando, Florida

MARCH 14-15, 2012

Fort Worth Convention Center
Fort Worth, Texas

Introducing the new conference and exhibition for the aerospace and defense industries

Featuring suppliers for the design and production of aerospace and defense products, including:

- ▶ Software
- ▶ Machinery
- ▶ Materials
- ▶ Components
- ▶ Sub-Assemblies
- ▶ Contract Services
- ▶ Electronics
- ...and much more!

For more information on attending or exhibiting, visit:

AeroConShows.com

Promo Code: AA



Produced and managed by UBM Canon | canontradeshows.com

17493_AS_Ae011

designideas

READERS SOLVE DESIGN PROBLEMS

High-side current-shunt monitor offers reduced error

Marián Štofka, Slovak University of Technology, Bratislava, Slovakia

▶ The circuit in **Figure 1** is an alternative to a high-side current monitor in a recent Design Idea (**Reference 1**). That monitor uses the Analog Devices (www.analog.com) AD8212 and an external high-voltage bipolar PNP transistor. The AD8212 can compensate for errors, which can reduce from the approximately -1% error of an uncompensated circuit to about -0.4%.

Circuit errors occur mainly because of the finite current gains of the two bipolar PNP transistors in the circuit: an external transistor and an internal low-voltage PNP transistor in the AD8212. The internal PNP transistor's base-emitter junction forms a negative-feedback loop for the op amp within the AD8212. Both PNP transistors form a cascade of two common-base-operated transistors. In the ideal case, the emitter current of the internal PNP, which is proportional to a sensed current, should equal the collector current of the external PNP.

This collector current mediates the information about the sensed current. In practice, however, the collector current of the external PNP transistor equals the emitter current of the internal PNP minus the sum of the base currents of both PNP transistors.

The base current is also a source of error in this circuit. The circuit reduces the undesired base current of the Darlington PNP by a factor of one divided by β_{PNP} compared with the circuit in the earlier Design Idea. In that Design Idea, β_{PNP} is the current gain of one PNP transistor. The circuit in **Figure 1** reduces error by using a PNP-to-Darlington connection in place of an external PNP transistor. The difference between the emitter and the collector currents in the Darlington connection is so low that you can omit compensation circuitry and the internal PNP transistor, which are associated with the compensation circuit. You could thus

DIs Inside

45 Make a quick-turnaround PCB for RF parts

46 PLL filter blocks undesired frequencies

46 Logic probe uses six transistors

▶ To see all of EDN's Design Ideas, visit www.edn.com/designideas.

integrate the two 1-k Ω resistors and the zener diode into a monolithic IC that is simpler than the AD8212.

The circuit in **Figure 1** uses an Analog Devices AD8603 op amp, which has a 40- μV input offset voltage. When its input voltage is close to the upper supply rail, the offset voltage is less than 200 μV . The worst-case input offset-voltage value would cause an additive error of 0.04% of the full-scale because the full-scale is 500 mV. IC₁'s subpicoampere input bias current rises at elevated temperatures to about 320 pA at 125°C, but that increase is still not significant enough to affect circuit accuracy. The same holds true also for the leakage current of the Darlington connection because the leakage currents flowing through the emitter and the collector of Q₂ have almost the same value. Leakage current I_{CE0} becomes a part of the feedback current that flows through resistor R_F.

When I_{CE0} rises, the op amp's output voltage goes slightly more positive. Feedback current I_F, flowing through resistor R_F, still remains constant. The only condition is that the minimum feedback current must be larger than the maximum leakage current. The selected PNP transistors allow V₊ to be as high as 30V. Q₁, an MMBT3906 type, exhibits a low drop in the value of current gain at low emitter currents. It

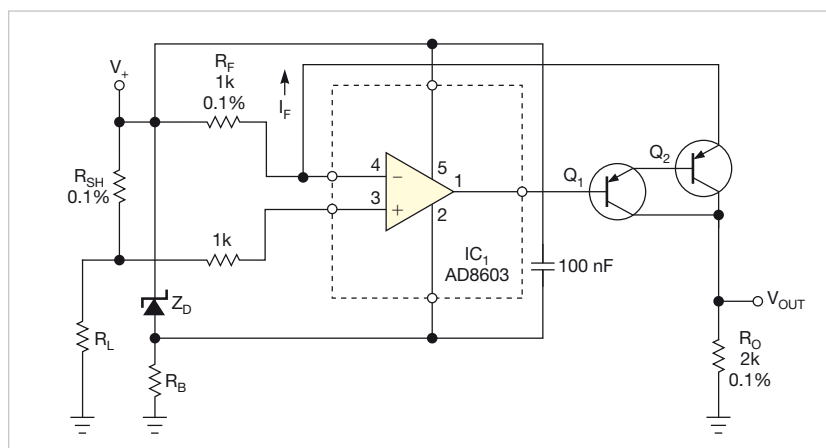
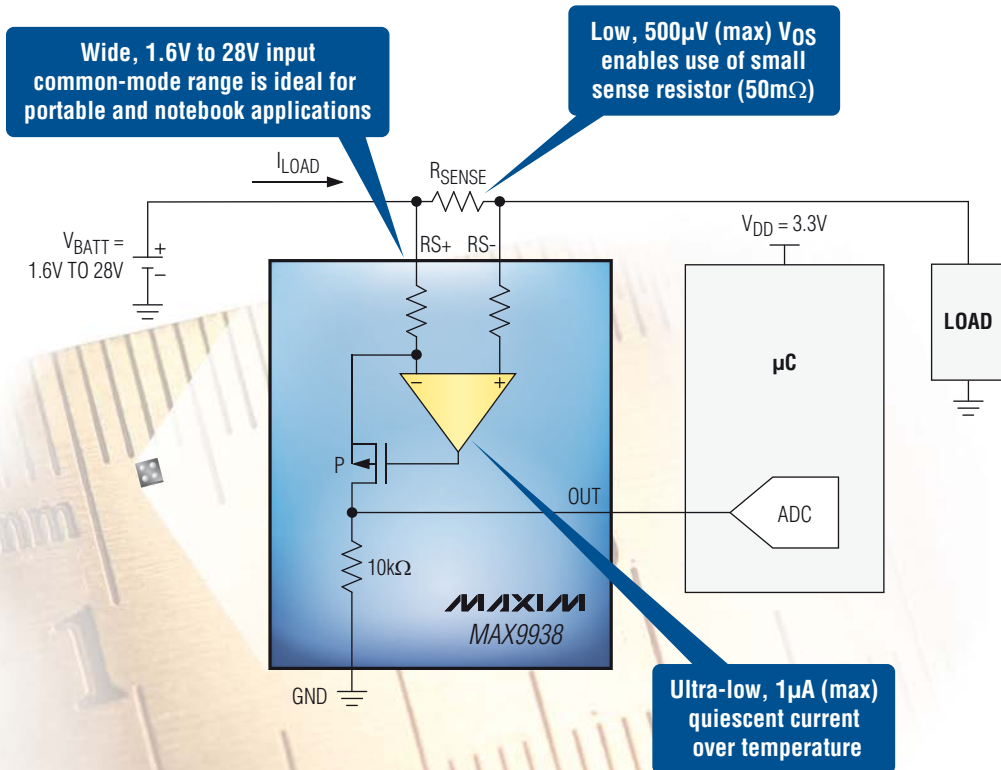

Figure 1 The circuit senses the current flowing through load resistor R_L at the high side and transfers it directly to the low side by means of feedback current I_F, which has 500 μA at full-scale.



Great things come in small packages

Industry's smallest current-sense amplifier



Tiny, 1mm x 1mm, 4-bump UCSP™ is 50% smaller than the competition

UCSP is a trademark of Maxim Integrated Products, Inc.

www.maxim-ic.com/MAX9938-info

**MAXIM
DIRECT.**

www.maxim-ic.com/shop

AVNET
electronics marketing

www.em.avnet.com/maxim

MAXIM
INNOVATION DELIVERED®

For free samples or technical support, visit our website.

Innovation Delivered and Maxim are registered trademarks of Maxim Integrated Products, Inc. © 2010 Maxim Integrated Products, Inc. All rights reserved.

drops to just 75% of its maximum value of 130 at an emitter current of $-100\ \mu\text{A}$. Q_2 is an MMBT4403 type.

For applications requiring higher values of V_+ , select PNP transistors having sufficient collector-emitter voltage ratings and increase the value of R_B as $R_B = (V_+ - 5\text{V}) / 5 \times 10^{-4}\text{A}$. Z_D , a ZPY5V6, has a zener voltage of about 4.7V at

about $500\ \mu\text{A}$. A test reveals that the relative difference between the emitter and the collector currents of the Darlington pair doesn't exceed 0.06% at full-scale. At 0.01 times full-scale, the relative error rises to 1.77%, indicating that the overall current-gain value of the Darlington decreases to about 56. The reduction of error lets you reduce the full-scale volt-

age at shunt resistor R_{SH} to 250 mV, reduce the power dissipated in R_{SH} by 50%, and maintain the error at 0.15%. **EDN**

REFERENCE

Tran, Chau, and Paul Mullins, "Current monitor compensates for errors," *EDN*, Sept 9, 2010, pg 47, <http://bit.ly/aFnEBW>.

Make a quick-turnaround PCB for RF parts

Steve Hageman, AnalogHome.com, Windsor, CA

Using low-cost PCBs (printed-circuit boards), you can easily design a board in a few hours with nearly any CAD package, even the free ones. You can have your prototype board on your desk in just two days. The design rules in many software packages are good, and most suppliers can fabricate a PCB with line width and spacing down to 0.006 in.

That precision is fine for low-frequency circuits, but RF circuits usually need $50\ \Omega$ traces for proper circuit operation. Parts get smaller, but the laws of physics don't change. Thus, a microstrip trace on a 0.062-in.-thick standard prototype board that was calculated to be 0.11 in. wide 30 years ago is still 0.11 in. wide today. Many surface-mount parts are far smaller than their predecessors, however, so it would seem that low-cost, two-layer prototype boards for RF prototyping are unsuitable for today's small SMT (surface-mount-technology) parts.

You can use a CPWG (coplanar-waveguide-over-ground) structure to build $50\ \Omega$ RF traces on PCBs. A CPWG structure lets you make the required trace width smaller than that of a microstrip structure.

Bringing a grounded copper ground plane on the top of the board closer to a microstrip trace adds capacitance to the microstrip structure. To compensate and to keep the entire structure at $50\ \Omega$, you must make the center trace more inductive by reducing its width—to a point.

How can you design the CPWG structure for a low cost and a fast PCB pro-

cess? You can find many online CPWG calculators, but they often fail when the ground-plane gap gets less than approximately 30 to 50% of the trace width because the height of the copper traces on the board becomes a significant factor. It adds more capacitance than the calculators assume. Hence, the lines these cal-

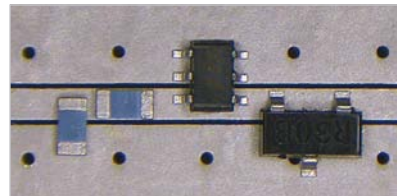

Figure 1 A nominally small SMT part fits well onto the 0.032-in.-wide CPWG $50\ \Omega$ line structure. The 0603 resistors and capacitors and a small gallium-arsenide FET-amplifier SC-70 IC also fit well.

culators design have too much capacitance, which reduces their impedance to less than $50\ \Omega$. The equations date back many years to IC design.

The equations in many calculators fall apart because today PCBs differ physically from ICs. The best way to properly design a CPWG on a PCB with a narrow gap-to-center-trace ratio is to use a full 3-D electromagnetic simulator. This Design Idea provides the values for a few common structures.

In keeping with the minimum trace-to-trace spacing of 6 mils, I simulated, built, and tested a CPWG structure. For a common 0.062-in.-thick FR-4 PCB material, a trace width of 0.032 in. with a gap of 0.006 in. is as close to $50\ \Omega$ as you can get. It provides better

than 40-dB return loss on the trace at 6 GHz.

This approach is better than using a 0.11-in.-wide trace and is compatible with SMT-sized parts. A 0603-sized SMT part and a common SMA (surface-mount-assembly) edge-launch connector fit the line perfectly. **Figure 1** compares several common RF-type parts with the fabricated PCB. For parts with larger pad dimensions than the 0.032-in. trace width, just increase the spacing to the top ground plane to compensate. For instance, increase the spacing to the top plane of a 0805 SMT pad to approximately 0.008 in. and increase the top-plane spacing for a 1206 SMT-component pad to 0.012 in. to keep the pad from being too capacitive.

In keeping with common design rules, I pulled back the copper planes on the tested PCBs 0.01 in. from the routed board edge. This pull-back and the edge-launch connector both add a slight amount of inductance to the transition, however. The big center pin of the edge-launch connector on top of the trace adds extra capacitance, providing built-in capacitive compensation. Cutting the pin to about half its original length yields about equal capacitance to balance the transition inductance.

The CPWG structure needs a solid ground plane under the trace; leaving cutouts in the bottom ground plane under the topside trace adds a significant inductance to the structure, which degrades high-frequency performance. You also need to "stitch" the top ground plane to the bottom ground plane with vias. Place the stitching vias less than one-eighth of a wavelength of the highest frequency that your circuit will use. Note that 0.1-in. spacing works well at frequencies greater than 10 GHz.

Spacing of the stitching vias to the center trace follows the same spacing rules. You can easily get enough vias in and around the trace to make it work.

If you don't have enough vias, you will see a slight but rapid 0.5- to 1-dB drop in the S_{21} transmission character-

istics instead of a linear loss slope with frequency. You can instantly see this effect by using a VNA (vector network analyzer). Measuring the test board shows approximately 0.25 dB/in. of loss at 3 GHz and 1 dB/in. of loss at 10 GHz, including two edge-launch connectors.

To interface to an SMT part or an IC with narrower pads than 0.032 in., narrow down the center conductor as needed as close to the part as possible. If the discontinuity is physically small, it will have little effect until very high frequencies. **EDN**

PLL filter blocks undesired frequencies

Stephen Kamichik, Ile Bizard, PQ, Canada

 You often need to block signals of specific frequencies; of these fre-

quencies, 50- or 60-Hz line frequency is the most common. You can use the PLL

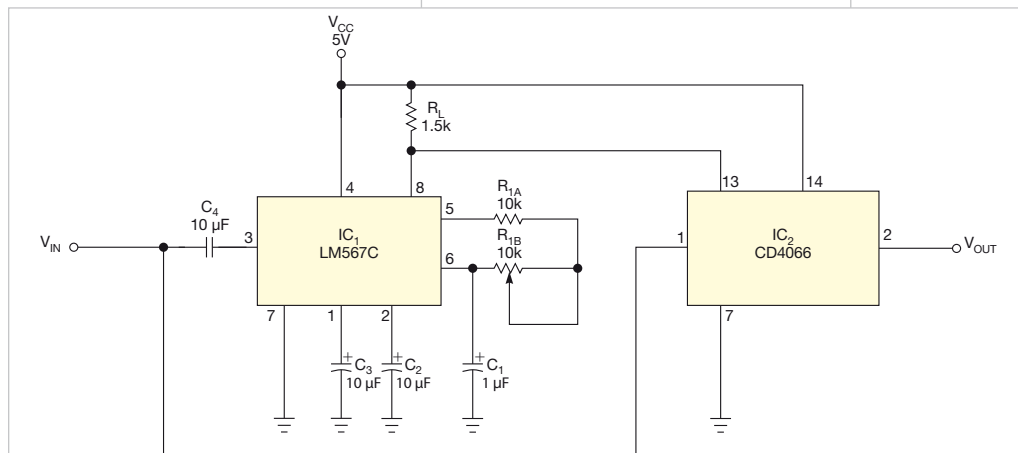

Figure 1 A tone decoder and a switch block frequencies that external components determine.

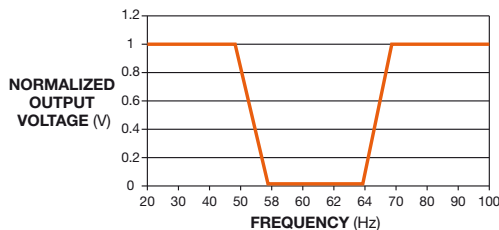

Figure 2 The components in Figure 1 block frequencies of approximately 60 Hz.

notch filter in **Figure 1** to block unwanted frequencies. IC₁, an LM567C, is a tone decoder. Components C₁, R_{1A}, and R_{1B} determine the frequency, F, that IC₁ detects: $F=1/[C_1(R_{1A}+R_{1B})]$. When you feed fre-

quency F to Pin 3 of IC₁, the output, Pin 8, goes low because the output transistor in IC₁ is saturated.

The LM567 decoder comprises an in-phase and quadrature detector, which a VCO (voltage-controlled oscillator) drives. The VCO determines the decoder's center frequency. The bandwidth of the decoder is $1070\sqrt{V/(C_2F)}$, where V is the rms (root-mean-square) input voltage and C₂ is capacitance in microfarads. The bandwidth is a percentage of the frequency.

The tone decoder's output runs to the control pin, Pin 13, of IC₂, a CD4066 quad bilateral switch. The input voltage connects to the CD4066's input pin, Pin 1. That signal controls the switch. The CD4066 switch is closed, or on, when the control pin is high at logic one and open, or off, when the control pin is low at logic zero. When IC₁ detects the unwanted frequency—in this case, 60 Hz—IC₁'s Pin 8 and, thus, IC₂'s Pin 13 go low. That action opens the switch, which blocks the signal with the unwanted frequency (**Figure 2**). **EDN**

Logic probe uses six transistors

Raju R Baddi, Raman Research Institute, Bangalore, India

 The circuit in **Figure 1** lets you build a logic probe using three NPN transistors and three PNP transistors. Two transistors act as switches that drive the LEDs; logic one is a green LED,

and logic zero is red. Q₁ and Q₂ test the probe-tip condition for logic one, and Q₃ and Q₄ test it for logic zero. Q₁ acts as a zener diode in the emitter circuit of Q₂. The voltage divider comprising R₁₂ and

R₁₄ determines the diode's value. That value creates a lower limit for the breakdown of the base-emitter junction of Q₂ through V_L. These values ensure that the threshold value for logic one at the probe tip is approximately 3.2V. Q₁'s breakdown voltage in the emitter circuit of Q₂ is approximately 2.6V. The equation for setting this threshold is $V_{HIGH}=1.2+(VR_{14}/$

$R_{12}+R_{14}$), where V is the supply voltage. Because V_{HIGH} is a function of the supply voltage, the probe is suitable for CMOS transistors, as well. When the voltage at the probe tip goes above this voltage, the base-emitter junctions of both Q_1 and Q_2 are forward-biased, and they have a common collector-emitter current that flows through R_4 , producing enough voltage to forward-bias Q_3 and turning on the green LED. Ideally, R_1 and R_2 maintain the voltage at the probe tip at approximately 2.5V, which is less than 3.2V.

Transistors Q_3 and Q_4 form a comparator of their base voltages. The divider combination comprising R_8 and R_9 maintains the base of Q_4 at a specific voltage, which is approximately 1.9V. Because the probe's suspended voltage is greater, Q_3 conducts, and no current flows through R_6 . Thus, Q_6 and the red LED are both off. If the voltage at the probe tip goes below 1.9V, however, Q_4 has a higher voltage at its base than Q_3 , and the common-emitter current

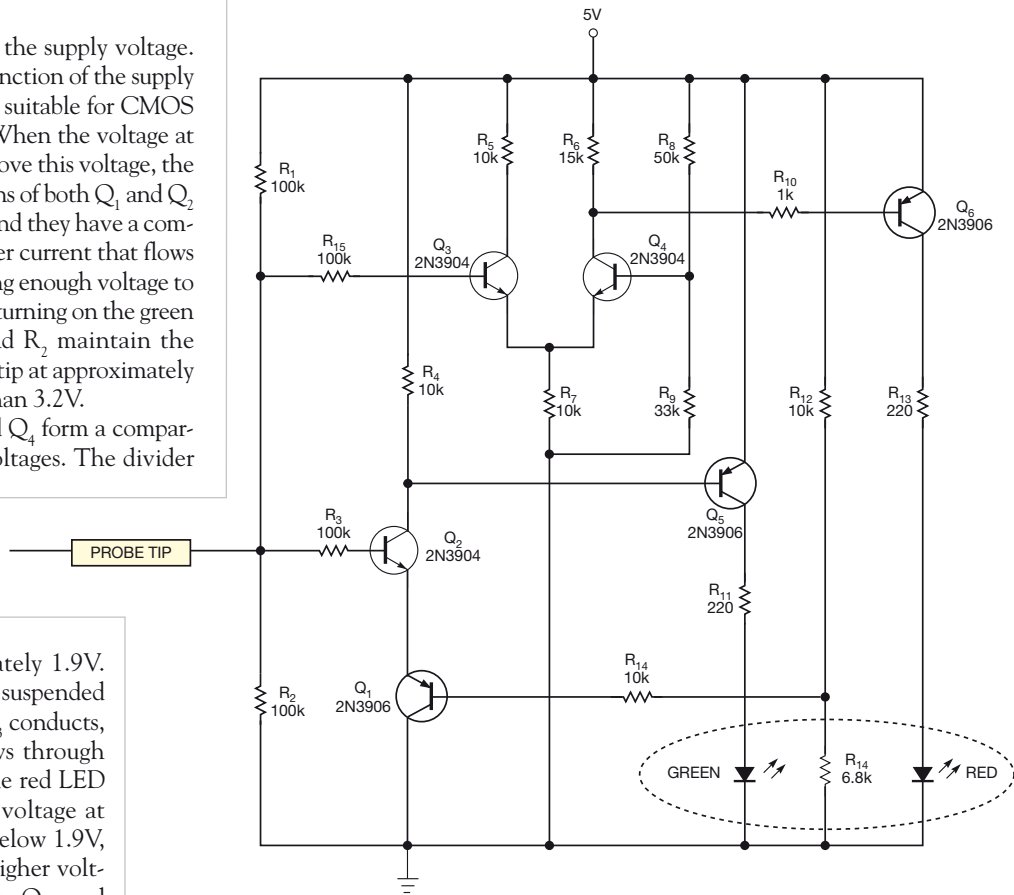
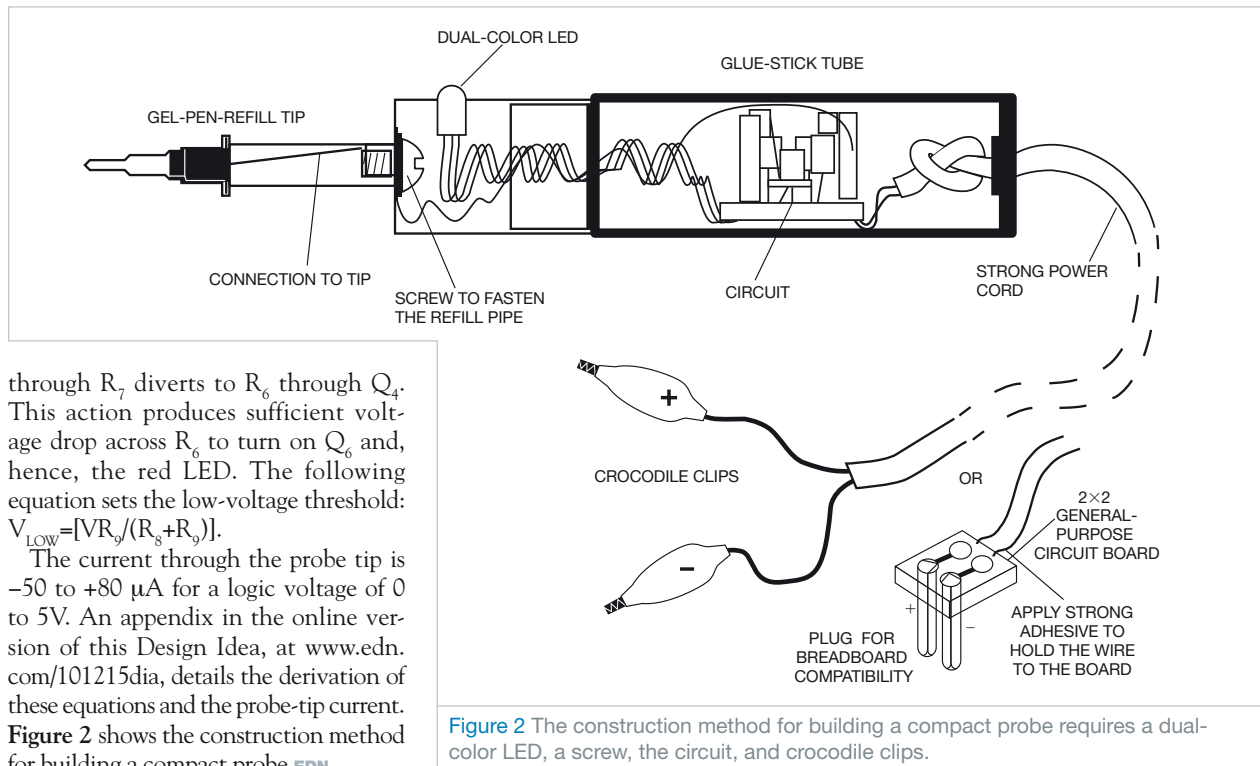

Figure 1 This circuit lets you build a logic probe using six transistors—three NPN and three PNP.



through R_7 diverts to R_6 through Q_4 . This action produces sufficient voltage drop across R_6 to turn on Q_6 and, hence, the red LED. The following equation sets the low-voltage threshold: $V_{LOW} = [VR_9 / (R_8 + R_9)]$.

The current through the probe tip is -50 to $+80 \mu A$ for a logic voltage of 0 to 5V. An appendix in the online version of this Design Idea, at www.edn.com/101215dia, details the derivation of these equations and the probe-tip current. Figure 2 shows the construction method for building a compact probe. EDN

Figure 2 The construction method for building a compact probe requires a dual-color LED, a screw, the circuit, and crocodile clips.

productroundup

POWER SOURCES



Isolated ac/dc converter has PFC

➔ The PFM VI brick-module isolated ac/dc converter has PFC and adaptive-cell architecture, which enables high efficiency of worldwide ac mains. The device delivers 330W at 48V in a 9.5-mm-thick profile. The module provides isolation, voltage transformation, and PFC regulation in one stage using high-frequency soft-switching technology. It sells for \$75 (OEM quantities).

Vicor Corp., www.vicorpower.com

400W dc/dc converter integrates a heat sink

➔ The VFK400 series of dc/dc converters provides 400W of output power. The chassis-mount devices integrate heat sinks for improved thermal performance. The 7.8×5×1.5 in. devices

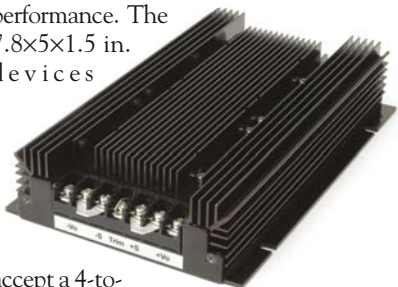

accept a 4-to-1 input and can support either 10 to 36 or 18 to 75V-dc isolated input voltages. The converters are available in regulated-output versions of 12, 24, and 48V dc. The devices are available through Digi-Key at \$388.94 (500).

CUI, www.cui.com

POL dc/dc converters tout 8.1A/cm² current density

➔ The DLynx family of nonisolated point-of-load, PCB-mounted dc/dc-power modules are available in DOSA (Distributed-Power Open Standards Alliance)-based digital and analog versions. They power silicon devices, such as processors and memory on PCBs. They also feature an industry-standard PMBus interface and an 8.1A/cm² current density. The family includes the 12A analog PVX012 PicoDLynx and 12A digital PDT012 PicoDLynx, which come in a standard 12×12-mm format. Input voltage ranges from 3 to 14.4V dc, and regulated-output voltage ranges from 0.6 to 5.5V dc.



Current derating over temperature enables the modules to achieve 10.4A at 85°C without any airflow from a 12V input to a 1.2V output. With as little as 100-lfm airflow, the DLynx delivers 12A full capacity at 85°C. All modules also include Tunable Loop technology, which allows users to optimize the dynamic response of the converter to match the load with a reduced amount of output capacitance. The modules use Power-One's digital-power-technology patents. Prices start at less than \$7 (OEM quantities).

Lineage Power,
www.lineagepower.com

100 and 150W power supplies accept wide ac-input range

➔ The 100 and 150W ZWS-BAF series of single-output, PCB-mountable ac/dc power supplies accepts a wide ac-input range. With profiles of 1.3 to 1.45 in. and footprints of 2.44×6.1 or 3×6.3 in., the devices target applications in light-industrial, LED-signage, test-and-measurement, gaming, point-of-sale, and IT equipment.

The open-frame supplies feature a universal 85 to 264V ac, 47- to 63-Hz input with PFC. They operate from a 120 to 370V-dc input. The units withstand 3 kV ac from input to output. The devices are available with output voltages of 3.3, 5, 12, 15, 24, or 48V dc, all of which have a ±10% adjustment range. Prices start at \$57 (500).

TDK-Lambda,
www.us.tdk-lambda.com/lp

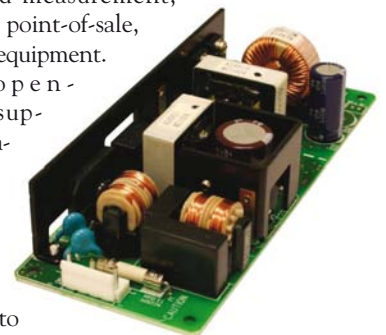

Three-terminal, 2A switching regulators feature efficiency as high as 92%

↘ The K78xx-2000 series of three-terminal switching regulators have input ranges of 4.75 to 18V dc, with positive or negative outputs of 2.5, 3.3, 5, and 6.5V dc. An output current as high as 2A allows for as much as



13W of power in a miniature SIP with a choice of straight or bent leads. Prices start at \$4.94 (OEM quantities).

Mornsun America,
www.mornsunamerica.com

Power converter targets energy-harvesting applications

↘ The TPS62120 step-down converter achieves 96% efficiency and can generate a 75-mA output current from an input voltage of 2 to 15V. The device targets use in energy-harvesting, battery-powered, and 9 and 12V-line-powered applications. The synchronous converter has a power-save mode to provide high efficiency over the entire

load-current range, reaching 75% efficiency at loads as low as 100 μ A. During light-load operation, the device consumes only

11 μ A of quiescent current. The device also automatically moves from power-save mode to a fixed-frequency PWM mode. Input voltage ranges from 2 to 15V, and output voltage ranges from 1.2 to 5.5V. The device also features smooth start-up from weak energy sources. The TPS62120 is available in an eight-pin, 3x3-mm SOT package and sells for 95 cents. Another version, the TPS62122, is available in an eight-pin, 232-mm QFN package and sells for \$1.05 (1000).

Texas Instruments, www.ti.com



EDN ADVERTISER INDEX

Company	Page
AdsanTec	26
Agilent Technologies	23
Analog Devices Inc	17
Cirrus Logic Inc	3
Coilcraft	9
CUI	31
Dell	4
Digi-Key Corp	C-1, C-2
Integrated Device Technology	12
International Rectifier Corp	7
Lambda Americas	37
Lattice Semiconductor	15
Linear Technology	C-4
MathWorks Inc	21
Maxim Integrated Products	44
Mouser Electronics	35
National Instruments	C-3
NPP Eilks	11
Panasonic Industrial	49
Pico Electronics Inc	6, 38, 39
Rohde & Schwarz	10
Stanford Research Systems Inc	28
Trilogy Design	49
UBM Canon Trade Events	42
Vicor Corp	19

EDN provides this index as an additional service. The publisher assumes no liability for errors or omissions.

EDN productmart

This advertising is for new and current products.



WIRELESS RF MODULES

Highly flexible, cost effective RF Modules for a wide variety of wireless Personal Area Network (PAN) applications. Extended range products featuring small footprints combined with revolutionary network firmware flexibility. Available in 802.15.4, Bluetooth®, ISM and Relative Position Awareness (RPA) technologies.



www.panasonic.com/indus/rf/

picomponentsmarketing@us.panasonic.com
1-800-344-2112



How to keep track of it all?

Easily create and manage multi-level parts lists and specs, calculate costs, generate shopping and kit lists, print labels, generate RFQs and POs and much more...

Parts & Vendors

3 editions starting at \$99 per user

Get the full function DEMO at www.trilogydesign.com

Parts List Manager & Vendor Database

The sharpest tool in the shed

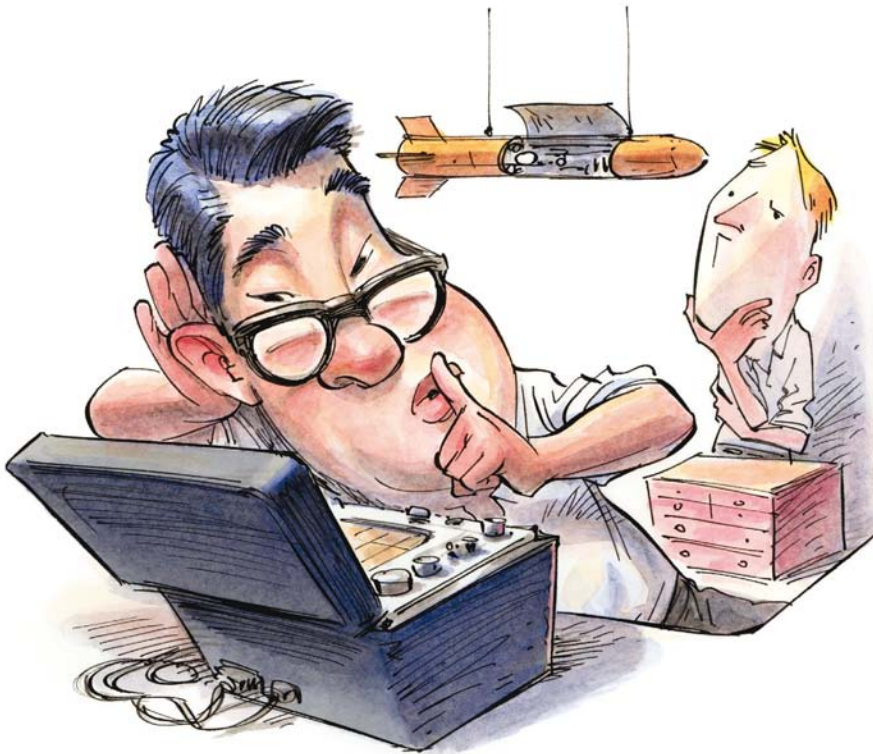

Quick to listen, slow to talk, and slow to anger are good rules to adopt in all your interpersonal relationships, but they also help when solving tough technical problems, and they helped in solving a problem I encountered five years ago while working in the electrical-engineering department of a sonar company. I got a call from the production manager, who asked if I could come by and help. One of our older systems had arrived at final test, and it couldn't pass the noise specifications. I greeted two of the best technicians I have ever worked with, and we got started.

I began with what I consider to be the two best tools in the toolbox: shut up and listen. Other systems of the same model and vintage were working fine; gleaning no clues from them, we moved on. A quick look revealed common-mode noise everywhere. Inserting bypass capacitors in selected places didn't help a bit. I checked other capacitors and grounds. Circuit grounds and other important connections were all in order, as well. This problem was going to be a tough one, but I reminded myself

that I love working on tough problems.

Taking another look, I noted that someone had replaced a switching power supply that ran the system with another vendor's model, but replacements did not always cause problems. One of the technicians had a lot of experience working on the systems in question and had noted a twofold problem with all of them: Whenever he installed the new board-mounted switching power supply, he had to mount it off the board so that he could

get the power-supply case to connect to an aluminum heat-sink block to connect the power-supply heat to the chassis. He had to mount it low enough for the power-supply pins to fit through the PCB (printed-circuit board) where it was mounted. Given what sounded like maybe a tolerance clue or just another kind of headache, we decided to take a closer look.

The OEM-provided potted power supply was in a five-sided metal case;

WITH A TEAM EFFORT—LISTENING FIRST, USING OUR TECHNICAL SKILLS SECOND, AND “EGOS GROUNDED” THIRD—WE QUICKLY MADE THE PROBLEM HISTORY.

the potted side was next to the power supply's PCB right against the traces that ran underneath the bottom of what looked like the unshielded side of the power supply. Seeing this setup gave me an idea. After quickly grabbing a couple ferrite slabs from some of our ferrite planar-transformer parts' stock, I asked the technicians to move the power supply off the PCB but to keep it connected properly. Slipping the two ferrite slabs into the open space provided enough attenuation to the radiated B field to clean up all the common-mode noise that had been coupling into the PCB's traces from under the power supply. We had to change the aluminum heat-conduction block in one dimension to make a good power-supply-to-chassis thermal connection, but we had cracked this tough nut of a problem, without a hammer, and we were done.

With a team effort—listening first, using our technical skills second, and “egos grounded” third—we had quickly made the dirty common-mode-system-noise problem history. **EDN**

Mark Garfinkel is a consulting engineer in Goleta, CA.

www.edn.com/tales

Fail Faster. Succeed Sooner.



Prototype Your Ideas Faster with NI Graphical System Design.

Through the large number of prototypes he created to get the first working light bulb, Thomas Edison taught engineers and scientists that building a functional prototype is fundamental in bringing ideas to life. NI LabVIEW graphical programming tools and NI customizable off-the-shelf hardware can transform an idea into a functional prototype in weeks, versus months, and lower the risk of your next project.

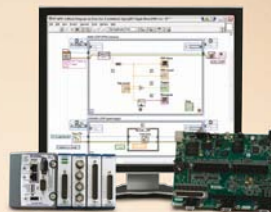

PRODUCT PLATFORM

NI LabVIEW

NI CompactRIO

NI Single-Board RIO

NI C Series I/O Modules

>> Get to market faster with prototyping tools at ni.com/succeed

888 279 9833



All the Highs & a Low

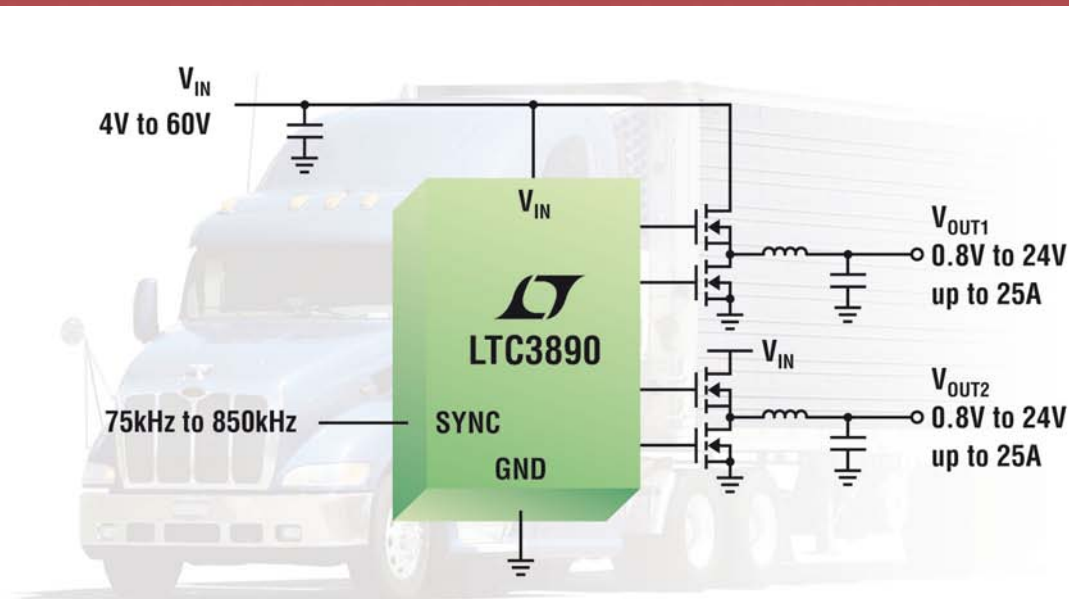

$60V_{IN}$, $24V_{OUT}$, $25A/Channel$, $850kHz$ & $I_Q = 50\mu A$

A new generation of dual synchronous, micropower step-down controller, the LTC[®]3890 offers performance and feature advantages for a broad range of power conversion applications. The 4V to 60V input capability covers a wide range of input sources and battery chemistries, protecting against high voltage transients so surge suppression circuits are not required. Minimum on-time of 95ns enables high step-down ratios. Its powerful 1.1 Ω onboard N-channel MOSFET drivers can deliver up to 25A of continuous output current per channel.

Features

- Input Voltage Range: 4V to 60V
- Dual Output Voltages: Up to 24V
- Up to 25A Output per Channel
- 95% Efficient
- Low Quiescent Current: 50 μA
- Multiphase Capable for Higher Output Current & Low Input Ripple
- High Step-Down Ratios
- R_{SENSE} or Inductor DCR Sensing
- Single Output Version: LTC3891

Efficiency vs Output Current (A)

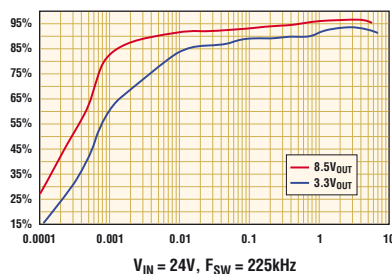

Info & Free Samples

www.linear.com/3890

1-800-4-LINEAR



www.linear.com/ad/3890

LT, LT, LTC, LTM, Linear Technology and the Linear logo are registered trademarks of Linear Technology Corporation. All other trademarks are the property of their respective owners.

